



SERVICE INSTRUCTIONS

1-800-KEATING • keatingofchicago.com

INSTALLATION FOR STAINLESS STEEL CUTTING BOARD WITH BRACKETS ON KEATING GRIDDLES

REQUIRED TOOLS:

- Drill Gun
- #24 Drill Bit
- Phillips Screw Driver
- 10-24 Tap

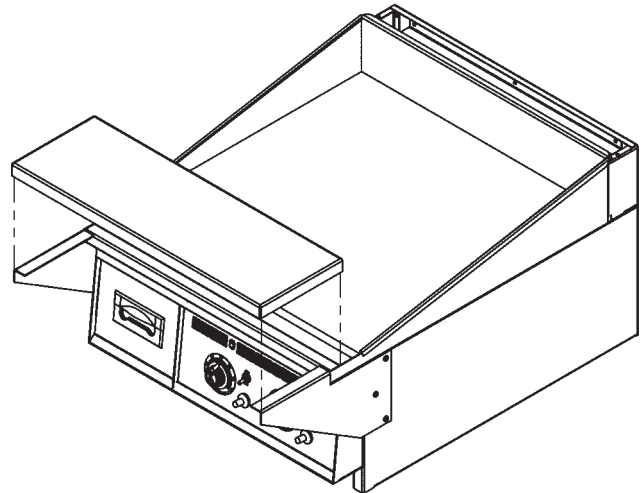
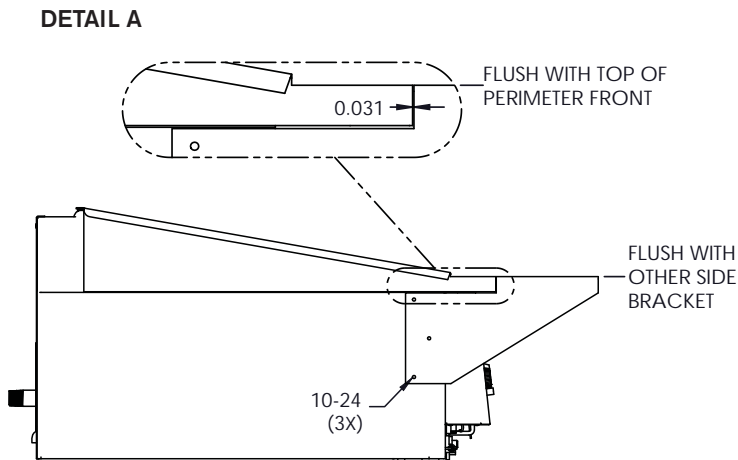

NOTE: When fully assembled, the cutting board should go over the perimeter front as well as the brackets tops.

INCLUDED IN YOUR PACKAGE:

- A** PRE-ASSEMBLED MOUNTING BRACKET FOR SECURING CUTTING BOARD TO SIDE BRACKET (2x)
- B** END SUPPORT BRACKET (2x)
- C** STAINLESS STEEL CUTTING BOARD (1x)
- D** #10 SCREWS FOR ATTACHING BRACKET TO CABINET (6x)
- E** CUTTING BOARD CENTER SUPPORT FOR 48" AND LARGER GRIDDLES (1x)

1. Hold the side mounting bracket in place (using orientation from Detail A), and mark the mounting holes on the cabinet sides. NOTE: Bracket tops must be as flat and parallel as possible for proper mounting of the cutting board.
2. Drill out marked holes in cabinet sides using a #24 drill bit, and then tap to 10-24.
3. Attach side brackets to cabinet sides using #10 x 1/2" screws provided.
4. Slide cutting board over brackets and perimeter front as shown above.