



Teppanyaki Griddle

PROJECT _____

QUANTITY _____

ITEM NO. _____

Standard Features:

- ▶ Ideal for presentation cooking
- ▶ Saves 44% in clean up
- ▶ Uniform heat distribution allows you to cook at lower temperatures, reducing shrinkage
- ▶ High input elements rated at 240 volts
- ▶ Reduced flavor transfer
- ▶ Zoned temperature control
- ▶ Electric only

Options:

- Stainless Steel Perimeter
- Trough Options
- Custom Griddle Styles or Configurations



Trough is Optional

The Keating Teppanyaki MIRACLEAN® Griddle is exclusively designed to meet the needs of your presentation cooking demands. The MIRACLEAN® plate will keep your Teppanyaki griddle looking clean and shiny even when not in use, and virtually eliminates flavor transfer.

Fits to you specifications

The griddle plate size is determined by customer specifications and can range from 24" x 24" to 72" x 30". Just provide us with a drawing of the table that will be used so that Keating can ensure a perfect fit. The actual heating section on all griddles is 24"W x 18"D and is available in electric only. Two high input elements rated at 240V are standard. The heating section is thermostatically controlled with one thermostat for each element. Keating does not manufacture the table.

Saves on energy costs

Documented energy savings of 32% by Pacific Gas & Electric means dollar savings of up to \$400 per year in energy costs on a 36" model. The MIRACLEAN® surface also reduces radiated heat loss to less than 10% of a conventional steel plate griddle. By keeping heat on the surface and out of the kitchen, the MIRACLEAN® Griddle reduces air conditioning demands and gives the chef a cooler cooking environment.

Saves 44% in clean up

A documented study by the University of Illinois General Engineering department confirmed what has long been known by MIRACLEAN® operators - cleaning the MIRACLEAN saves time! 44% savings means less labor cost and high productivity. Cleaning a 36" MIRACLEAN versus a conventional steel plate model 3x daily would mean savings of \$2,600 over the life of the unit. Cleaning the surface takes 3 easy steps:

1. scrape with the Keating scraper
2. wash with a Keating palmetto brush and water
3. polish with Keating Klenzer and a damp cloth

No more griddle bricks, grill screens or harsh chemicals needed, and reseasoning the plate is not necessary.

Accurate temperature control

MIRACLEAN® Griddles feature zoned temperature control to ensure temperature accuracy in cooking. The MIRACLEAN® surface allows the operator to cook at lower temperatures to control the degree of caramelization and product shrinkage.



As continuous product improvement occurs, specifications may be changed without notice.

DATE _____

APPROVAL _____

SIGNATURE _____

www.keatingofchicago.com

Teppanyaki MIRACLEAN® Electric Griddle



Teppanyaki Griddle

A minimum of 24" at the front of the unit should be allowed for servicing and operation; a minimum of 6" on each side and at the rear of each unit for combustible materials.

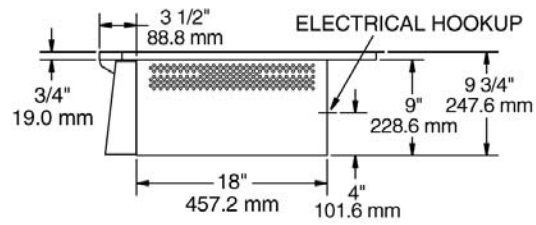
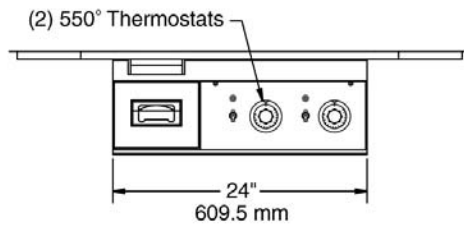
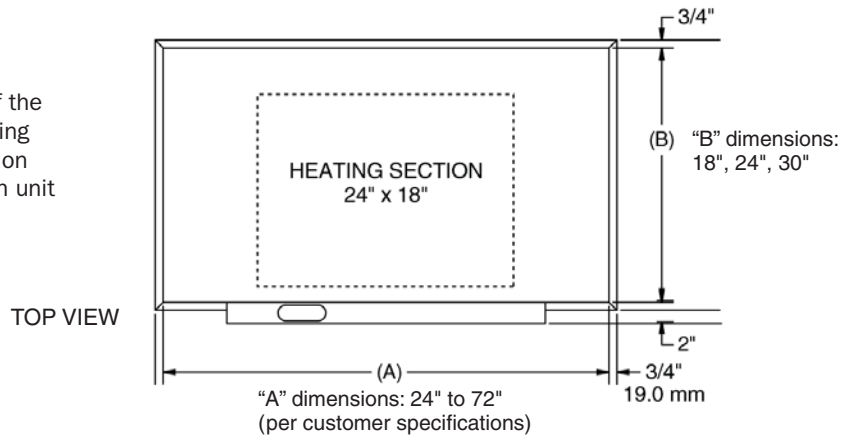

SPECIFICATIONS

Griddle Plate - High carbon, 3/4" steel plate with our patented Trivalent Chromium surface applied in a special 8-step process to ensure a mirror smooth surface. The MIRACLEAN® plate has an emissivity rating of .078.

Drain Trough (Optional) - An optional front drain trough with a 4" x 1-1/2" drain in the left front (unless otherwise specified). It is located above a large stainless steel grease drawer with baffles and a rear handle. The grease trough is 14 gauge stainless steel.

Electric Elements - Two high input, stainless steel elements rated 7.9 kW at 240 volts. Each element is encased in insulation and held tightly in place with a molded steel cover.

Thermostat - Close range, hydraulic type thermostat, accurate to ±5° from 250° to 550°F, with one thermostat for each element. Application of this thermostat is patented by Keating.

Standard Accessories - Keating long handle palmeto brush, egg turner and sample of Keating Klenzer.

Electric Specifications - 3 wire terminal block with ground for field wiring. (See local codes for supply line requirements.)

Special Order Options - Trough options, Stainless Steel perimeter, and custom griddle styles and configurations.

NOTE - The customer must provide a drawing of the table that will be used, and the table must be ventilated. (Keating does not manufacture the table.)

ELECTRICAL REQUIREMENTS			
kW	Volts AC	1-Phase Amps	3-Phase Amps
5.9	208	28	14-25-14
6.6	220	30	15-26-15
7.9	240	33	16-28-16
6.6*	480	---	7-12-7

* 480V is optional and must be specified.

NOT FOR OUTDOOR INSTALLATION - NOT FOR DOMESTIC INSTALLATION

As continuous product improvement occurs, specifications may be changed without notice.

www.keatingofchicago.com

Teppanyaki Electric Griddle