



Drop-In Gas Pasta™ System

PROJECT _____

QUANTITY _____

ITEM NO. _____

Standard Features:

- ▶ Available in natural gas or LP gas
- ▶ Saves on time and space
- ▶ Automatic water fill
- ▶ Stainless Steel cabinet
- ▶ Polished Stainless Steel fryer vessel
- ▶ Patented cook cycle
- ▶ Two digital timers for precise cooking control
- ▶ Starch overflow drain

Options:

- Basket-Lift
- Individual Serving Baskets



Floor Model Unit Shown

Keating offers a Custom Pasta™ Cooking System designed to meet the needs of every kitchen. With our Drop-In Pasta™ Cooking System, water comes to a rolling boil in less than 10 minutes. The Drop-In Pasta™ Cooking System can cook up to six pounds of dry pasta per load, yielding 110 lbs. of pasta per hour.

High production

The Custom Pasta™ Cooking System has the highest energy input of any unit on the market today. A “pre-heat” cycle utilizes the full energy input for fast pre-heating. Keating’s patented “cook cycle” manages energy input, which maintains a rolling boil throughout the cooking process. This means you can more easily accommodate rush orders. The starch overflow drain eliminates starch build up for better cooking results.

Safe and easy to use

The Custom Pasta™ Cooking System is a self-contained, self-filling and self-draining system. Keating’s water auto-fill feature automatically refills the cooker when water level is low without affecting the boil. A panel of indicating lights for water filling, power or pilot on, and burners on monitors the status of the unit at all times.

Versatility

The Custom Pasta™ cooks more than just pasta - it's ideal for boiling seafood, blanching vegetables, poaching eggs, cooking reconstituted meals and much more. With Keating’s wide assortment of baskets available, you can prepare individual servings as well as large portions, plus you can cook different shapes and sizes of pasta to perfect consistencies.



As continuous product improvement occurs, specifications may be changed without notice.

DATE _____

APPROVAL _____

SIGNATURE _____

www.keatingofchicago.com

Drop-In Gas Pasta™ System

KEATING
OF CHICAGO, INC.

Drop-In Gas Pasta™ System

A minimum of 130 square inches unobstructed vent area near pasta cooker required for combustion.

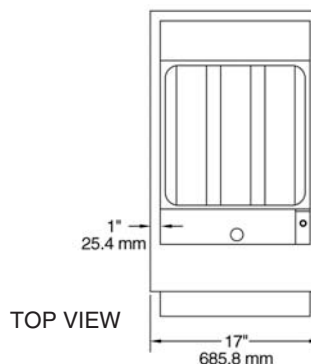
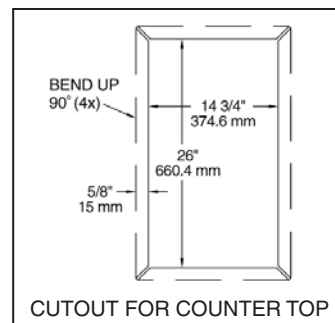
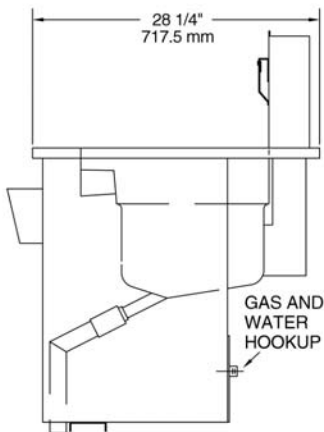
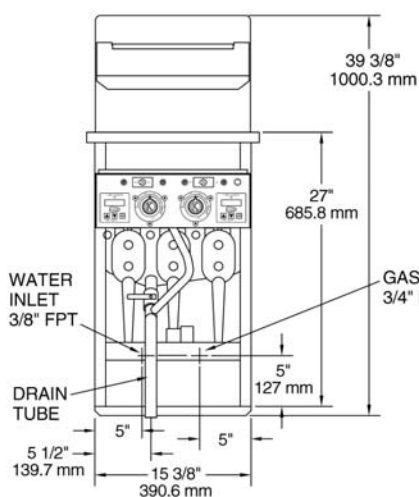

Description - The Keating Drop-In Pasta™ System can be ordered in natural gas or LP gas.

SPECIFICATIONS

Water vessel is made of 18 gauge highly polished stainless steel. The gas model holds 5.5 gallons of water.

Cabinet - The cabinet, including the splashback and the splashdeck, is made of 16 gauge stainless steel.

Thermostats - Patented "cook cycle" features dual thermostats, to maximize preheat while controlling the boil. The range is 100° to 250°F.

Water Auto-Fill - Two sensors control the water auto-fill. The upper sensor activates the solenoid valve to fill the unit to the proper level. The lower sensor prevents the burners from coming on if the water level is below it to prevent heat damage to the unit. The unit also has a manual fill button to allow additional water to flow into it when needed and has a standard 3/8 inch female pipe connection on the rear. Maximum incoming water pressure cannot exceed 60 psi.

Starch Overflow - Starch overflow is located in the front of the water vessel and ensures excess starch and foam are regularly drained off. Used in conjunction with the manual water fill, it can also permit flushing of greater amounts of water when needed.

Indicating Lights - Indicating lights located on the front control panel indicate water filling, power on or pilot on and burners on.

Drain - The drain terminates 5" from the floor and requires an open or trapped drain, per local and national codes.

Baskets - Baskets are perforated and are available in both full and split styles.

Timers - Each unit comes with two 15 minute digital solid state timers.

Gas Connection - The gas connection is in the rear of the unit, and is a 3/4 inch male NPT connection. Natural gas requires a 4" water column pressure and LP a 10" water column pressure. A pressure regulator, rated at 1/2 psi is built into each unit.

Special Order Options - Basket-lift and individual serving baskets.

INSTALLER - Check plumbing and gas codes for proper gas supply line sizing to sustain burner pressure when all gas appliances are full on. Supply pressure must NOT be above 13.84" WC or gas valve damage may occur.

GAS REQUIREMENTS AND DIMENSIONS

MODEL	BTU INPUT/ BURNER	Height	Depth	Width	Weight
14 PASTA DI NAT GAS	109,000	39 3/8"	28 1/4"	17"	125 lbs.
14 PASTA DI LP GAS	109,000	39 3/8"	28 1/4"	17"	125 lbs.

Note: See drawing for specific utility notes, drain location and cutout dimensions for counter top.

NOT FOR OUTDOOR INSTALLATION - NOT FOR DOMESTIC INSTALLATION

As continuous product improvement occurs, specifications may be changed without notice.

www.keatingofchicago.com

Drop-In Gas Pasta™ System