



24" MIRACLEAN® GAS GRIDDLE

"Serving Those Who Serve The Very Best"®

- 100% customer satisfaction
- Saves 44% in clean up
- Cooler kitchen
- Low temperature cooking high heat transfer reducing shrinkage
- Saves 32% in energy costs
- Reduced flavor transfer
- Zoned temperature control
- No electrical connections needed
- Many options available

The Keating MIRACLEAN® Griddle is designed to provide maximum performance with many benefits to the operator. The mirror surface of the MIRACLEAN® is achieved in a special eight step process. High input burners rated at 30,000 BTU/hr. for natural gas are mounted every 12" to ensure performance and recovery allowing the operator to use zone cooking for different products.

SAVES ON ENERGY COSTS

Documented energy savings of 32% by Pacific Gas & Electric means dollar savings of up to \$400 per year in energy costs on a 3-ft. model. The MIRACLEAN® surface also reduces radiated heat loss to less than 10% of a conventional steel plate griddle. By keeping heat on the surface and out of the kitchen, the MIRACLEAN® Griddle reduces air conditioning demands and gives the chef a cooler cooking environment.

REDUCES FLAVOR TRANSFER

The smooth MIRACLEAN® surface prevents food particles from being trapped as they are in steel plate griddles. The surface virtually eliminates flavor transfer.



**Stand with casters or 4" legs are optional*

SAVES 44% IN CLEAN UP

A documented study by the University of Illinois General Engineering department confirmed what has long been known by MIRACLEAN® operators that cleaning the MIRACLEAN® saves time! 44% savings means less labor cost and higher productivity. Cleaning just a three foot MIRACLEAN® versus a conventional steel plate model three times daily would mean savings of \$2,600 over the life of the unit! Cleaning a MIRACLEAN® surface takes just three easy steps: scrape with the Keating Scraper, wash with a Keating Palmetto brush and water, and polish with Keating Klenzer and a damp cloth. No more griddle bricks, grill screens or harsh chemicals are needed, and reseasoning the plate is not necessary.

ACCURATE TEMPERATURE CONTROL

MIRACLEAN® Griddles feature zoned temperature control to ensure temperature accuracy in cooking. The MIRACLEAN® surface allows the operator to cook at lower temperatures to control the degree of caramelization and product shrinkage.



24" WIDE MIRACLEAN® GAS GRIDDLE



DESCRIPTION

The Keating MIRACLEAN® Griddle consists of a griddle plate, having a drain trough and perimeter installed in a cabinet equipped with gas burners. An automatic temperature control mechanism and 100% safety shut off are all arranged and designed for the proper cooking of food on a griddle surface.

SPECIFICATIONS

Griddle Plate to be made of high carbon, 3/4" steel plate upon which a trivalent chromium surface has been applied in a special eight step process to ensure a mirror smooth surface. The MIRACLEAN® plate has an emissivity rating of .078.

Drain Trough 24x30FT and 24x36FT have front trough only. The drain is located above a large stainless steel grease drawer with baffles and a rear handle. The perimeter and grease trough are 14 gauge stainless steel. The perimeter is 4 1/2" high across the back with sides angling from 4 1/2" in the rear to 1/2" at the front. Sides and rear perimeter have an exterior trim of 22 gauge stainless steel.

Gas Burners to be "H" shaped cast iron construction, atmospheric type with one burner for every 12" of linear plate surface. Each pilot is manually ignited with a (piezo) igniter.

Cabinet to have an inner liner of 20 gauge aluminized steel. Outer cabinet 14 gauge stainless steel sides, 18 gauge stainless steel back and 16 gauge aluminized steel bottom. A stainless steel flue deflector is shipped with every unit.

Thermostat to be millivolt sealed contacts, close range, hydraulic type, accurate to ± 5° from 250° to 550°F. Application of this thermostat is patented by Keating.

100% Safety Shut Off to be millivolt, thermocouple type with 100% safety shut off.

Standard Accessories to include Keating razor scraper with a packet of 10 blades, 4" wide spatula, long-handle palmetto brush, egg turner, can of Keating Klenzer.

Electrical Connections are not required.

Gas Requirements to install are 3/4" male NPT connection and 4" (natural gas) and 10" (LP gas) water column pressures. Supply pressure must be 7" (natural gas) and 11" (LP) water column.

Special Order Options may include 4" legs, stand, stand with shelf and casters, cutting board: stainless, richlite, plate shelf, thermostat knob guard, belly bar, streaked surface, custom griddle styles and configurations, security package.

Model	BTU/hr. NG	BTU/hr. LP	Burners	T-Stats	(A) Overall Width	(B) Depth	Height	Working Height	(C) Plate Size	Ship Wt.
24x30 FT	60,000	60,000	2	2	24 1/2"	30 3/8"	18"	12"	24"Wx24"D	265 lbs.
24x36 FT	73,000	73,000	2	2	24 1/2"	36 3/8"	18"	12"	24"Wx30"D	275 lbs.

FT = Front Trough Only

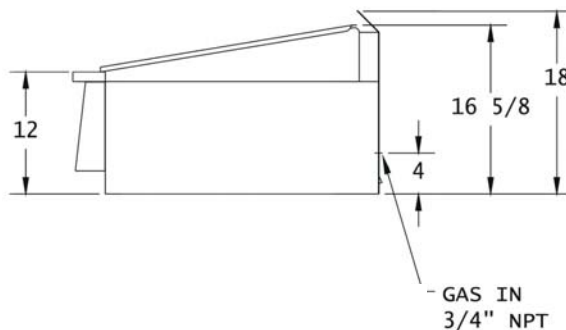
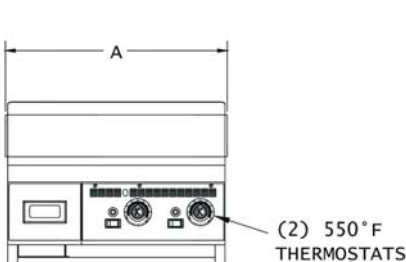
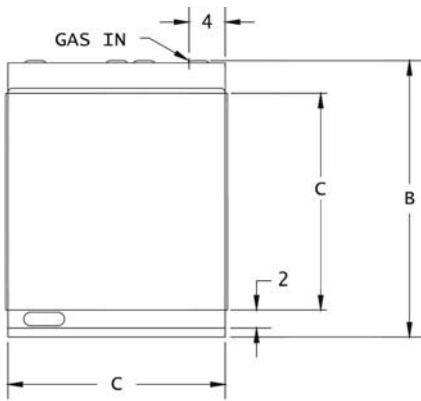

**NOT FOR OUTDOOR INSTALLATION
NOT FOR DOMESTIC INSTALLATION**

As continuous product improvement occurs, specifications may be changed without notice.



KEATING OF CHICAGO, INC.
Toll Free 1-800-KEATING
www.keatingofchicago.com