



## SAFE & EASY CENTRAL FILTER®

*"Serving Those Who Serve The Very Best"®*

- Provides safe filtration
- Stainless Steel bagging station
- Saves oil costs
- Improves product quality
- Easy to use
- High speed pump
- Now available with 34×24 Fryers



\*Common installation: 18" Safe & Easy Central Filter® with 3-18 TS BL Fryers and optional Flat Top Preparation Area.

The Keating Safe & Easy® Central Filter is designed to minimize oil breakdown and extend oil life. The closed "hands free" system means that you never come in contact with hot oil during the filtration process. Completely contained within its own cabinet, Keating's Safe & Easy® Central Filter assures safe and proper handling of hot oil.

### SAVE ON OIL COSTS

Keating's Safe & Easy® System combines the advantages of low temperature cooking, Cold Zone sedimentation and a one-step, multi-layered filter to purify oil. Cooking temperature, moisture and oxidation are the main causes of oil breakdown. Filtering conditions oil and removes free fatty acids, which if done on a regular basis, extends the life of the oil.

### FAST AND EASY FILTRATION

The high capacity pump filters five gallons of oil per minute. Simply open the drain valve, switch on the filter pump and close the drain valve. The Safe & Easy® Central Filter does the rest. With the patented swirling action, crumbs, debris and contaminants are removed and oil is purified. When solidified shortening is present, the optional melt cycle safely melts it to prevent it from clogging the filter.

### EFFECTIVELY REMOVES FOOD PARTICLES

The multi-layered filtration system removes food particles. The strainer basket separates large crumbs from the oil and traps them before entering the filter. The remaining oil is conditioned by Keating's Acidox filtering compound to remove fatty acids and then pumped through filter paper to remove any remaining debris. Simply dump the crumbs and lift out the paper to complete the filtering process.

### FAST AND CONVENIENT

With no additional equipment to store, no special attachments to put in place and no special steps to rinse down the fryer, the Safe & Easy® Central Filter helps you filter quickly and without hassle. Depending on your fryer size, five minutes is all you need. When filtering a battery of fryers, you can filter one fryer while the others are still in operation for non-stop production.



SAFE & EASY CENTRAL FILTER®

**DESCRIPTION**

The Keating Safe & Easy® Central Filter is a “hands free” system which requires no contact with hot oil. The system is designed to utilize the natural sedimentation of the Instant Recovery® Fryer. Oil is drained through a valve and drain pipe in rear of the fryer. It passes through a strainer basket, Acidox powder and filter paper before returning to the fryer through a closed pipe system. The oil enters the bottom of the fryer in a swirling motion which rinses the sediment into the filter while minimizing aeration.

**SPECIFICATIONS**

**Performance:** Central filter may be installed in a battery of up to six fryers (no more than three per side). Since only one fryer is out of operation at a time, filtration may be conducted at any time. Filtration time depends on fryer size.

**Filter drawer** shall be removable on bearing rollers with 20% more shortening capacity than largest fryer in battery. Filter drawer holds strainer basket, screen, hold down ring and spring loaded arms to hold paper in place. A sump and 3/8" pipe return the filtered oil to the closed pipe system.

**Drain valve** to be rear drain with front release. 14" models to have 1" drain valve, 18"-24" models to have 1 1/4" drain valve and 34"x24" model to have (2) 1 1/4" drain valve.

**Return valve** to be located above drain valve. It activates the Safe & Easy® Central Filter closed pipe return system.

**Drain pipe** to be 1 5/8" on 14" model, 2" on 18"-24" models (2) 1 1/4" on 34"x24" model. To prevent blockage, no sharp bend 90 degree elbows or fittings are used.

**Safety switch** to provide 100% fryer shut off prior to filtration. Switch is activated when drain valve is opened.

**Filter Paper** to be exclusively designed to fit in filter tub.

**Hold Down Ring** keeps filter paper in place.

**Pump** to be 1/2 horsepower rated, capable of pumping up to five gallons of oil per minute.

**Hose and Wand:** The hose and wand are provided for discarding shortening. Hose length varies with number and size of fryers.

**Standard Accessories** to include recessed dump station over filter with stainless steel perforated screen, one package filter paper (60 sheets), and one carton of Acidox filter compound (60 packages).

**Electrical Requirements** to be 120V, 5.6 amps for the pump circuit. The use of heat tape will add up to 3.1 AMPS depending on length of heat tape used.

**Special Order Options** may include Keep Krisp® food warmer mounted over prep area, heat tape for solid shortening, 220V is available (special- not certified).

Model No.	No. of Fryers	Oil Capacity	Voltage	HP	AMPS	Height	Depth	Width	Filter Time	Ship Wt.
SE14CF	1	50 lbs.	120	1/2	5.6	46 1/2"	32 5/8"	15 3/8"	1.5 min.	170 lbs.
SE18CF	1	90 lbs.	120	1/2	5.6	46 1/2"	36 5/8"	19 3/8"	2.5 min.	190 lbs.
SE20CF	1	120 lbs.	120	1/2	5.6	46 1/2"	38 5/8"	21 3/8"	3.5 min.	210 lbs.
SE24CF	1	160 lbs.	120	1/2	5.6	46 1/2"	42 5/8"	25 3/8"	4.5 min.	230 lbs.
SE34x24CF	1	210 lbs.	120	1/2	6	46 1/2"	42 5/8"	35 3/8"	6 min.	250 lbs.

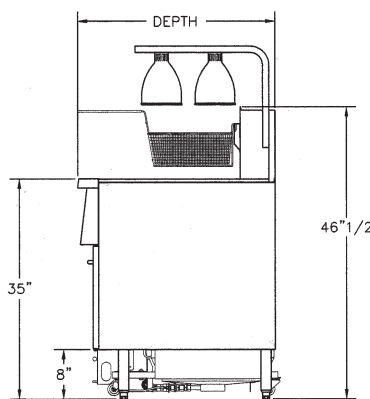
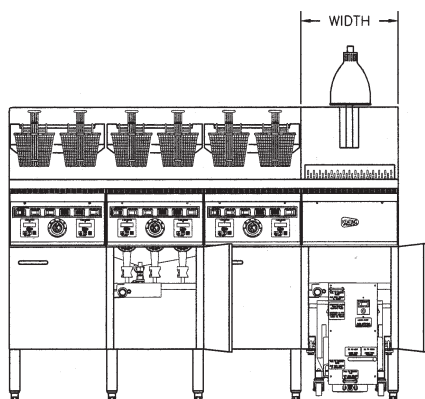
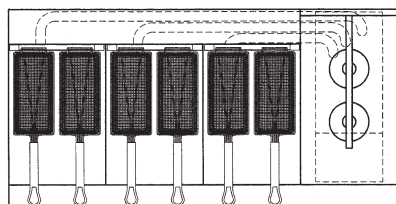

KEATING OF CHICAGO, INC.  
Toll Free 1-800-KEATING  
www.keatingofchicago.com

As continuous product improvement occurs, specifications may be changed without notice.