



**PORTABLE FILTER  
MODELS PC14, LB100,  
LB165, LB200**

# MANUAL

■ **IMPORTANT:**

**THIS MANUAL PROVIDES SPECIFIC OPERATING INSTRUCTIONS FOR YOUR MODEL. USE THE KEATING PORTABLE FILTER ONLY AS INSTRUCTED IN THIS MANUAL.**

---

**KEEP A COPY OF YOUR BILL OF SALE.**

The date on the bill establishes the warranty period should service be required. If service is performed, it is in your interest to obtain and keep all receipts.

---

**KEEP THIS MANUAL FOR TRAINING NEW PERSONNEL.**

---

Record the Serial number and Model number of this Portable Filter in the spaces provided. **Keep these numbers for future reference.**

SERIAL NUMBER

MODEL NUMBER

**Keating commercial filters are not intended for household use.**

**As continuous product improvement occurs, specifications may be changed without notice.**

---

**1-800-KEATING | [keatingofchicago.com](http://keatingofchicago.com)**

**⚠ CAUTION**

**HOT FLUID. DO NOT FILL BEYOND MAXIMUM FILL LINE LOCATED IN THE FRYER VESSEL.**



## ■ TABLE OF CONTENTS

<b>INTRODUCTION</b> .....	<b>1</b>	<b>DISASSEMBLY</b> .....	<b>6 - 7</b>
Damage During Shipment .....	<b>1</b>	Melt/Pump Indicator Lights .....	<b>6</b>
<b>OPERATING INSTRUCTIONS</b> .....	<b>1</b>	Melt/Pump On/Off Switch .....	<b>6</b>
Preparing the Portable Filter .....	<b>2</b>	Melt Cycle Sensor .....	<b>7</b>
Filtration .....	<b>2</b>	Heater Elements .....	<b>7</b>
Clean-Up .....	<b>3</b>	Pump and Motor .....	<b>7</b>
Melting Solid Shortening .....	<b>3</b>	Heat Tape .....	<b>8</b>
Filter Failure .....	<b>4</b>	<b>SERVICE PARTS ORDERING</b> .....	<b>9</b>
<b>WARRANTY REPAIRS</b> .....	<b>4</b>	<b>PARTS LIST</b> .....	<b>9 - 10</b>
<b>SERVICE DIAGNOSIS</b> .....	<b>5</b>	Ordering Parts .....	<b>9</b>
Trouble Shooting Chart .....	<b>5</b>	Warning and Operating Plates .....	<b>9</b>
Preventative Maintenance .....	<b>6</b>	<b>WIRING DIAGRAMS</b> .....	<b>11 - 15</b>
<b>SERVICE</b> .....	<b>6</b>	<b>WARRANTY INFORMATION</b> .....	<b>16</b>

## ■ INTRODUCTION

*Instructions in this manual should be read thoroughly before attempting to operate the Portable Filter. All installation and service on Keating equipment must be performed by qualified, certified, licensed and/or authorized installation or service personnel.*

*Operating information for Keating equipment has been prepared for use by qualified and/or authorized personnel.*

*Keating equipment is made in the USA and has American sizes of hardware. All metric conversions are approximate.*

## ■ OPERATING INSTRUCTIONS

Proper installation will assure top performance. Alterations of any kind to your equipment will void the warranty. Before uncrating, check equipment carefully for damage.

### IF EQUIPMENT ARRIVES DAMAGED

***Keating does not assume responsibility for loss or damage incurred in transit.***

### IMPORTANT

This merchandise has been thoroughly inspected and carefully packed before leaving our plant. Responsibility for its safe delivery was assumed by the carrier at the time of shipment. Claims for loss or damage to the contents should, therefore, be made upon the carrier, as follows:

### CONCEALED LOSS OR DAMAGE

Concealed loss or damage means loss or damage which does not become apparent until the merchandise has been unpacked. The contents may be damaged in transit due to rough handling even though

the carton may not show external damage. When the damage is discovered upon unpacking, make a written request for inspection by the carrier's agent within fifteen days of the delivery date. Then file a claim with the carrier since such damage is the carrier's responsibility. By following these instructions carefully, we guarantee our full support of your claims to protect you against loss from concealed damage.

### VISIBLE LOSS OR DAMAGE

Any external evidence of loss or damage must be noted on the freight bill or express receipt, and signed by the carrier's agent. Failure to adequately describe such external evidence of loss or damage may result in the carrier refusing to honor a damage claim. The form required to file such a claim will be supplied by the carrier.

**DO NOT RETURN DAMAGED MERCHANDISE TO KEATING. FILE YOUR CLAIM AS STATED ABOVE.**

## PREPARING THE PORTABLE FILTER

1. Remove screen from over tubes/element with tongs or a Drain Clean Out Rod (See Figure 1-1).

### DRAIN CLEAN OUT ROD

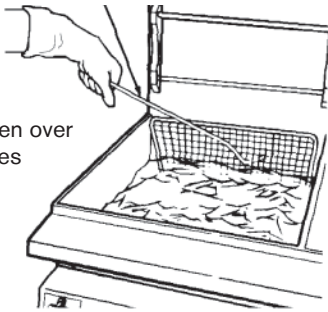

Figure 1-1  
Remove screen over elements/tubes

## CAUTION

**SCREEN OVER TUBES/ELEMENTS WILL BE VERY HOT AND SHOULD BE MOVED TO A SAFE PLACE.**

2. Heat fryers to 325°F. Stir oil thoroughly until all water is removed and shut fryer off (including pilot light) before filtering (Figure 1-2).

**NOTE:** Water settles in the cooler oil in the Cold Zone. If the water is not removed, the filter paper absorbs the water preventing the oil from passing through it.

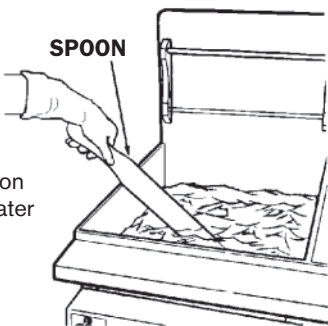

Figure 1-2  
Stir with spoon to remove water

3. Use the spoon and stir oil thoroughly until bubbling stops, resulting in removal of all water (Figure 1-2).

## WARNING

**OIL IS HOT. USE CARE WHEN FILTERING.**

4. Place in clean filter tub (See Figure 1-3):

- 1st: Filter Screen
- 2nd: Filter Paper (new sheet for each fryer)
- 3rd: Hold down ring
- 4th: Secure hold down ring at each corner with "T" rod handles
- 5th: Acidox filter powder (new powder for each fryer)
- 6th: Strainer basket

Figure 1-3  
Assemble filter

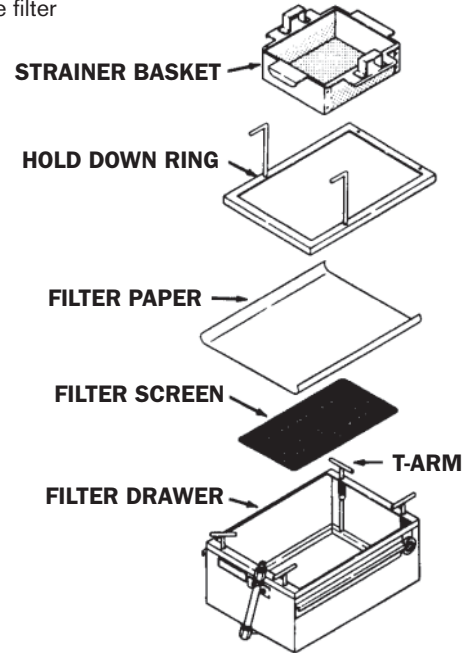

**NOTE:** Hold down ring makes a gasket-like seal on filter paper. Filter paper must be placed edge to edge from front to back, overlapping on sides. Filter Paper must be smooth and flat under hold down ring to get a proper seal. Lock the two tension arms into place by pushing down and rotating 90°.

**NOTE:** One package of Acidox is needed for every 40 lbs. of oil.

5. Completely shut off fryer (main and pilot on gas models or main electrical power on electric models) before proceeding with filtration.

## FILTRATION

1. Oil being filtered is hot. Use proper protective attire and caution to prevent injury.
2. Plug filter into a suitable electrical power source.

Figure 2-1  
Drain fryer

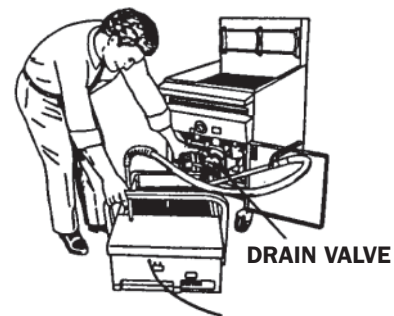

3. Open fryer cabinet door and position portable filter vessel under fryer drain valve. Slowly open drain valve to avoid splashing and permit oil in fryer vessel to drain into filter vessel (Figure 2-1).

4. Direct end of filter wand into fryer vessel and then place filter MELT/OFF/FILTER toggle switch to FILTER position. If oil does not flow through wand and into fryer vessel, position toggle switch to MELT position for ten minutes to melt any oil in filter lines/hoses. Then place toggle switch to FILTER position.

5. For a period not to exceed twenty minutes, direct wand to flush all crumbs and other residue out of fryer vessel and from splashdeck into filter vessel (Figure 2-2). Operating the motor-pump for more than twenty minutes may overheat the motor, tripping the motor internal overload switch. If this occurs, it will be necessary to permit the motor to cool down for five to ten minutes and then press the reset switch at the rear of the motor. The reset switch is accessible through the button plug opening at the right side of the filter.

**Figure 2-2**  
Flushing fryer vessel

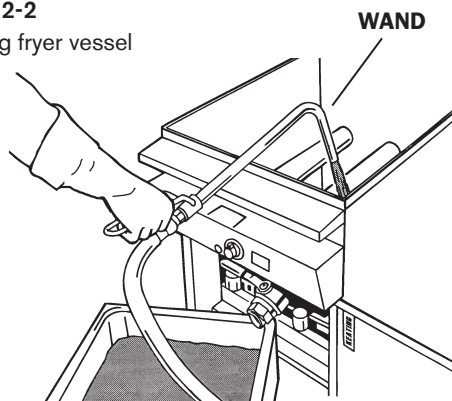

6. Repeat this procedure as necessary until fryer vessel is completely flushed out. Partially close drain valve to permit fryer vessel to fill above tubes/elements permitting swirling action to rinse down fryer vessel.

**Figure 2-3**  
Close drain valve

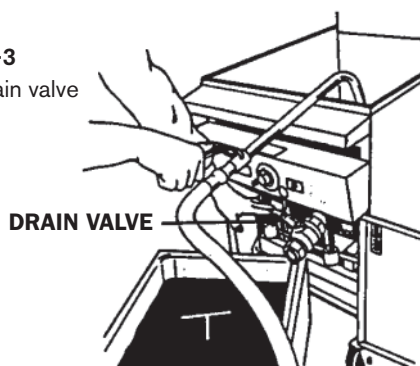

7. Close fryer drain valve (See Figure 2-3).
8. Clean fryer vessel with non-abrasive scrub pad & Keating Klenser.
9. Fill fryer with filtered oil by turning on pump and directing end of wand into vessel (See Figure 2-4).

**NOTE:** Filters with two-way pump - do NOT place wand in cold zone of fryer pot as it may pick up crumbs & other debris and excessively clog filter paper.

**Figure 2-4**  
Fill fryer with filtered oil

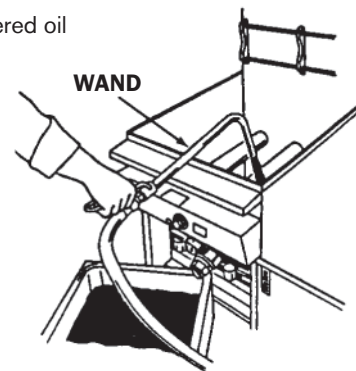

10. Operate pump for approximately thirty seconds after filter vessel is empty to clear any residual oil from the filter's lines/hoses. This will prevent blockage resulting from solidified oil during subsequent filtering operations.

**CLEAN-UP**

**⚠ WARNING**

**FILTER UNIT AND PIPES WILL REMAIN HOT FOLLOWING FILTRATION. ALLOW THE UNIT TO COOL DOWN BEFORE CLEAN-UP. FAILURE TO DO SO MAY RESULT IN SERIOUS INJURY TO THE OPERATOR.**

1. Turn MELT/OFF/FILTER toggle switch to "OFF" position and disconnect from electrical source.
2. Remove strainer basket and hold down ring for cleaning.
3. Remove and discard filter paper and any residue.
4. Clean filter tub thoroughly.
5. Coat inside of pump with oil if water has been running through it.
6. Place hose so that remaining oil will drain out.
7. Move filter to storage and close fryer cabinet door. Start up fryer in accordance with technical manual provided with fryer.

**MELT SOLID SHORTENING**

1. Clean filter tub and remove all accessories.
2. Place a cube of shortening in filter tub.
3. Turn fat melter on. (50 lbs. takes 1 hr. to melt)
4. Once shortening is melted fill fryer with oil by turning on pump and directing end of wand into vessel (See Figure 2-4).

**⚠ CAUTION**

**DO NOT ALLOW SHORTENING TO SOLIDIFY IN FILTER AS IT WILL ALSO SOLIDIFY IN PIPES.**

## **⚠ CAUTION**

**DO NOT TURN ON FAT METER WITHOUT SHORTENING IN TUB.**

## **⚠ WARNING**

**DO NOT USE TO TRANSPORT HOT OIL. FILTER HAS BEEN DESIGNED TO FILTER OIL INDOORS ONLY.**

### **FILTER FAILURE**

If filter will not pump, solidified shortening may have plugged pipes. Turn on fat melter for 20 minutes. This will heat filter tub and pipes to free system of solidified shortening. Reset motor before attempting filtering (reset button is located on rear of pump motor.)

### **WARRANTY REPAIRS**

Keating's 1 year parts & labor warranty begins with the date of installation.

In the event that your filter, under warranty, needs repairs other than routine cleaning, you are requested to contact KEATING OF CHICAGO, INC. (1-800-KEATING) before calling a local service company.

## **⚠ CAUTION**

**HOT FLUID. DO NOT FILL BEYOND MAXIMUM FILL LINE LOCATED IN THE FRYER VESSEL.**

## ■ SERVICE DIAGNOSIS

The following diagnosis is only to be used as a guide to qualified service personnel. Keating recommends that you use a qualified & licensed service company. (Equipment still under warranty requires it.)

**NOTE:** To correctly and quickly diagnose the system, the chart below should be followed in sequential order.

### TROUBLE SHOOTING CHART

PROBLEM	PROBABLE CAUSE	SOLUTION
Motor runs but will not pump oil	<ul style="list-style-type: none"> <li>a. Solidified shortening may have plugged pipes.</li>   <li>b. Tub not set up properly.</li> </ul>	<ul style="list-style-type: none"> <li>a. Turn on fat melter for 20 minutes. This will heat filter tub and pipes to free system of solidified shortening. Reset motor before attempting filtering (reset button is located on rear of pump motor).</li>   <li>b. Place components in tub per the following:                             <ul style="list-style-type: none"> <li>1. Filter screen on the very bottom.</li> <li>2. Filter paper over filter screen (Lie it flat on the bottom, creasing the sides).</li> <li>3. Hold down ring (ensure paper is not folded, lock hold down ring into place ensuring a tight seal).</li> <li>4. Sprinkle Acidox powder evenly over filter paper (1 bag per 40 lbs. of oil).</li> <li>5. Strainer basket for large debris.</li> </ul> </li> </ul>
Motor does not operate	<ul style="list-style-type: none"> <li>a. Not plugged in.</li>   <li>b. Motor has overheated.</li>   <li>c. Motor pump is clogged.</li> </ul>	<ul style="list-style-type: none"> <li>a. Plug filter into a 120 or 220 Vac electrical power source. Turn ON/OFF switch to 'ON'.</li>   <li>b. Allow motor to cool for approximately 10 minutes. Press the motor overload reset button and try again.</li>   <li>c. Call a qualified service technician to clean your pump. Clogged motor pumps are not covered by warranty.</li> </ul>

## **PREVENTATIVE MAINTENANCE**

Preventative maintenance should be performed during & after each use of the filter. Following preventative maintenance procedures will help to keep your filter working efficiently. Proper care & servicing will lead to years of quality performance.

### **Familiarize yourself with the proper filtering procedure prior to attempting to filter:**

1. To remove water, stir oil until bubbling stops; water will clog filter paper pores.
2. Use only one sheet of filter paper properly sealed under hold down ring.
3. Do NOT turn on fat melt without oil in filter tub.
4. Use a drain clean out rod if partial or full blockage in fryer drain is suspected.
5. If filter was used for fryer boil out, run oil through filter to lubricate motor/pump.
  
6. Clean filter and all components after each use. Do not permit oil to remain in filter drawer; it will clog the pump.
7. Verify all lights and controls operate.
8. Adhere to operating instructions in sequence given for proper filtration.
9. Prepare filter for next use by using new filter paper and Acidox Powder for each fryer.

## **■ SERVICE**

### **DISASSEMBLY**

#### **You will need:**

**Adjustable wrench**      **"Stubby" screwdriver**  
**Standard pliers**        **Standard screwdriver**

Servicing should only be performed by qualified and licensed service companies. Always disconnect the electrical power cable before attempting any service

### **⚠WARNING**

**THE FILTER MAY BE HOT; USE CARE WHILE SERVICING. AS A SAFETY PRECAUTION, IT IS RECOMMENDED YOU DRAIN OIL FROM THE FILTER VESSEL BEFORE PERFORMING ANY SERVICING.**

#### **A. MELT AND/OR PUMP INDICATOR LIGHTS**

##### **Removal:**

1. Disconnect filter from electrical power source.
2. Feel front end panel from bottom to locate rear of defective indicator light. Note two tangs that extend slightly beyond indicator light barrel diameter. Use a standard pliers to squeeze tangs together and pull indicator light free from panel. If indicator light doesn't release, squeeze tighter and break barrel to release electrical leads. Discard broken pieces.

##### **Replacement:**

1. If necessary, clip off electrical leads as close as possible to indicator light. If leads were clipped, trim off insulation 1/8 inch from end.
2. With electrical leads extending through panel front, press them into recesses at rear of replacement indicator light to secure them in place. Press indicator light into panel until tangs engage to secure indicator light to panel.

#### **B. MELT AND/OR PUMP ON/OFF SWITCH**

##### **Removal:**

1. Disconnect filter from electrical power source.
2. Unscrew nut securing defective switch to panel. Push switch in to release from panel. Remove nameplate from front of panel.
3. Access to rear of switch through bottom hole under front end panel.
4. Disconnect leads from switch. Tag leads as they are disconnected to assure, during replacement, they are reconnected to the proper switch terminals.

##### **Replacement:**

1. Connect tagged electrical leads to replacement switch.



2. Insert replacement switch through panel from which defective switch was removed. Insert nameplate over toggle and secure to panel with nut supplied with switch. Orient switch and tighten nut to secure in desired position.
3. Plug in filter power cord and operate switch to verify switch orientation corresponds to nameplate legend. If not, loosen attaching nut and reorient nameplate and/or switch as desired and retighten nut.

### C. MELT CYCLE SENSOR

#### Removal:

1. Disconnect filter from electrical power source.
- NOTE:** Remove all oil from filter vessel. Filter must be positioned on its end to access melt cycle sensor.
2. Raise front (power cord) end of filter and rest filter on oil absorbing rags on its back end.
  3. Remove bottom cover attaching screws; remove bottom cover.
  4. Remove electrical leads from defective melt cycle sensor.
  5. Loosen heater element cover attaching nut adjacent to melt cycle sensor sufficiently to release melt cycle sensor and its retaining plate. Disengage melt cycle sensor.

#### Replacement:

1. Orient replacement melt cycle sensor in its retaining plate such that the metallic sensing surface will be in direct contact with filter vessel. If necessary, reverse orientation of retaining plate.
2. Position retaining plate under heater element and tab on heater element cover with melt cycle sensor sensing surface in direct contact with filter vessel. Tighten loosened heater element attaching nut.
3. Attach removed electrical leads to melt cycle sensor. Verify terminals are not in contact with any metallic parts of filter vessel, heater cover or heater.
4. Secure bottom cover with removed attaching screws.
5. Position filter right-side-up and clean up oil absorbing rags.

### D. HEATER ELEMENT(S)

#### Removal:

1. Disconnect filter from electrical power source.
- NOTE:** Remove all oil from filter vessel. Filter must be positioned on its end to access heater element(s).
2. Raise front (power cord) end of filter and rest filter on oil absorbing rags on its back end.
  3. Remove bottom cover attaching screws; remove bottom cover.

4. Remove electrical leads from defective heater element(s). Tag leads as they are disconnected to assure, during replacement, they are reconnected to the proper terminals.
5. Loosen heater element(s) cover attaching nuts sufficiently to release defective heater element(s). Carefully remove heater element(s) being careful not to dislodge cover insulator(s).

#### Replacement:

1. Carefully position replacement heater element(s) between filter vessel and cover insulator(s).
2. Tighten loosened heater elements cover attaching nuts to secure heater element(s) in position against filter vessel.
3. Connect tagged electrical leads to heater element(s).
4. Secure bottom cover with removed attaching screws.
5. Position filter right-side-up and clean up oil absorbing rags.

### E. PUMP AND MOTOR

#### Removal:

1. Disconnect filter from electrical power source.
- NOTE:** Remove all oil from filter vessel. Filter must be positioned on its end to access pump and motor.
2. Disconnect hand hose assembly from quick disconnect on discharge port on defective pump and motor.
  3. Raise front (power cord) end of filter and rest filter on oil absorbing rags on its back end. Remove bottom cover.
  4. Remove attaching screws securing front panel. Tilt back front panel to expose pump and motor.
  5. Remove motor junction box cover and remove electrical leads from motor terminals. Tag leads as they are disconnected to assure, during replacement, they are reconnected to proper terminals.
  6. Unscrew coupling nut securing suction tube under filter vessel from plumbing connected to pump and motor suction port. Oil absorbing rags should be available as some oil spillage should be expected.
  7. While supporting pump and motor, remove attaching nuts, flat washers and screws; remove pump and motor. Note orientation of plumbing elbows at pump suction port and then unscrew these parts.
  8. Remove motor junction box cover and disconnect electrical leads from motor terminals. Tag leads as they are disconnected to assure, during replacement, they are reconnected to the proper terminals.

**Replacement:**

1. Install removed plumbing parts into replacement pump and motor suction port in same orientation noted at removal using teflon tape or a good food grade pipe joint compound on male threads only of disassembled plumbing parts.
2. Position pump and motor onto its base and secure loosely with removed screws, flat washers and nuts.
3. Connect tagged electrical leads to motor terminals. Install motor junction box cover.
4. Tighten suction tube coupling nut onto mating pump suction port fitting. Then fully tighten pump and motor mounting hardware.
5. Position front panel onto frame and secure in position. Install bottom cover.
6. Position filter right-side-up and clean up oil absorbing rags.
7. Connect hand hose assembly to quick disconnect on discharge port.

**F. HEAT TAPE****Removal:**

1. Disconnect filter from electrical power source.  
**NOTE:** Remove all oil from filter vessel. Filter must be positioned on its end to access heat tape.
2. Raise front (power cord) end of filter and rest filter on oil absorbing rags on its back end.
3. Remove bottom cover attaching screws; remove bottom cover.
4. Sketch course defective heat tape follows to assure oil and various components can be sufficiently heated during filter operation preventing any solidification. Then remove heat resistant mastic tape holding heat tape to filter components.
5. Remove hardware securing heat tape ends to electrical terminals. Unwind heat tape from filter components.

**Replacement:**

1. Wind replacement heat tape onto and around filter components following same course of removed defective heat tape.
2. Secure heat tape ends to electrical terminals with removed hardware.
3. Use a heat resistant mastic tape to secure heat tape in place on filter components.
4. Secure bottom cover with removed attaching screws.
5. Position filter right-side-up and clean up oil absorbing rags. (See Cleaning Instructions)

■ SERVICE PARTS ORDERING

Parts may be ordered by part number by calling Keating at 1-800-KEATING or your service company. We recommend using genuine Keating Replacement Parts - engineered and manufactured specifically to meet exact specifications and requirements for Keating equipment.

Refer to the Keating Filter Limited Warranty for complete service and ordering information.

The model/serial plate is located on the side of the unit. The model and serial numbers are necessary when ordering.

WARNING AND OPERATING PLATES

All warning and operating plates on the Portable Filter should be in place at all times. If plates are damaged or lost, replace them immediately.

■ PARTS LIST - PORTABLE FILTER

MODEL LB100

DESCRIPTION	P/N
CASTER 3" SWIVEL (after 2003)	000626
CASTER 3" RIGID (pre 2003)	000627
COVER for LB100	
2000 Series	056273
Pre 2000 Series, Optional	000503
FILTER SCREEN LB100 (12 1/4 dia.)	000591
INDICATING LIGHT	
Amber	004158
Red	000525
HANDLE for COVER	004542
HEAT PLATE, 500 W 115V	000596
HEAT WRAP TAPE, 4' for LB/PC Filters	012055
HI-LIMIT SENSOR	060164
HOLD DOWN RING HANDLE	052817
HOLD DOWN RING LB100	000576
HOLD DOWN RING LB100 (after 1/2003)	054803
HOSE, 4' w/fittings & Stiffner Spring for PC14 (for LB Filters prior to 2/3/93)	000569
HOSE, 5' w/fittings for LB Filters after 2/3/93)	018157
INSULATION BOARD	007694
NOZZLE, 90° with Handle for LB/UFF Filters	011816
POWER CORD, 6' with plug	055241
**PUMP/MOTOR (after 11/88)	008196
**PUMP/MOTOR (after 2003)	059896
SPRING for T HANDLE	006656
STRAINER BASKET LB100 (old style)	000668
SWITCH (Pump/Off/Melt)	000521
SWITCH REVERSING (2-Way Pump)	000527
TERMINAL BOARD	000639
TERMINAL BOARD INSULATION	000263



SUPPLIES

DESCRIPTION	P/N
ACIDOX POWDER (30 lb. case, 60 individual packages)	037524
DRAIN CLEAN OUT ROD	004622
FILTER PAPER	
LB100 (60 papers)	058783
LB165 or LB200 (60 papers)	058781
PC14 (60 papers)	058779
PADDLE METAL SPOON	029152
SEA POWDER (for boiling out fryers)	
4 jar case	000394
4 jar case (6 cases and up)	000395

\*\*Call 1-800-KEATING with serial number to determine correct part #.

## ■ PARTS LIST - PORTABLE FILTER (Cont.)

### MODEL LB165

DESCRIPTION	P/N
CASTER 3" SWIVEL (after 2003)	000626
CASTER 3" RIGID (pre 2003)	000627
CORD	055241
COVER for LB165	055676
HANDLE for COVER	004542
HEAT PLATE, 500 W 115V	000596
HEAT WRAP WIRE, 4' 100W 120V	012055
HI-LIMIT SENSOR	060164
HOLD DOWN RING (pre 2000)	016121
HOLD DOWN RING (pre 2003)	054654
HOSE (complete with Quick Disconnect)	055038
INDICATING LIGHT	
Amber	004158
Red	000525
INSULATION BOARD	007694
POWER CORD RECEPTACLE	055227
<b>**PUMP/MOTOR (after 2004)</b>	059986
<b>**PUMP/MOTOR (2003)</b>	052982
<b>**PUMP/MOTOR (pre 2003)</b>	008196
SCREEN	001229
SPRING for T HANDLE	006656
STRAINER BASKET LB165	000677
SWITCH (Pump/Off/Melt)	000521
SWITCH REVERSING (2-Way Pump)	000527
TERMINAL BLOCK	002065
TERMINAL BOARD	000639
TERMINAL BOARD INSULATION	000263

**\*\*Call 1-800-KEATING with serial number to determine correct part #.**

### MODEL PC14

DESCRIPTION	P/N
CASTER 3" SWIVEL (after 2003)	000626
CASTER 3" RIGID (pre 2003)	000627
CORD, 6' POWER	006315
HANDLE 'T'	010628
HEAT PLATE 500W 115V	000596
HEAT WRAP WIRE, 4' 100W 120V	012055
HI-LIMIT SENSOR	060164
HOLD DOWN RING	011370
HOSE, 4' with nozzle & fittings	017640
INDICATING LIGHT, Red	000525
INSULATION BOARD	007694
PUMP/MOTOR	008196
SCREEN	005871
SPRING for 'T' HANDLE	006656
STRAINER BASKET PC14	012054
SWITCH (Pump/Off/Melt)	000521
TERMINAL BOARD	000639
TERMINAL BOARD INSULATION	000263

### MODEL LB200

DESCRIPTION	P/N
CASTER 3" SWIVEL	000626
COVER for LB-200	056180
HANDLE for COVER	004542
HEAT PLATE, 500 W 115V	000596
HEAT WRAP WIRE, 4' 100W 120V	012055
HI-LIMIT SENSOR	060164
HOLD DOWN RING (after 2004)	055033
HOLD DOWN RING (pre 2000)	016121
HOLD DOWN RING (pre 2003)	054654
HOSE, 5' with fittings	055038
INDICATING LIGHT	
Amber	004158
Red	000525
INSULATION BOARD	007694
POWER CORD RECEPTACLE	055227
<b>**PUMP/MOTOR (after 2004)</b>	059986
<b>**PUMP/MOTOR (2003)</b>	052982
<b>**PUMP/MOTOR (pre 1993)</b>	008196
<b>**PUMP/MOTOR (1993)</b>	010567
SCREEN	001229
STRAINER BASKET LB200	016305
SWITCH (Pump/Off/Melt)	000521
SWITCH REVERSING (2-Way Pump)	000527
TERMINAL BOARD	000639
TERMINAL BOARD INSULATION	000263
VALVE (2-way pump)	000611

**\*\*Call 1-800-KEATING with serial number to determine correct part #.**

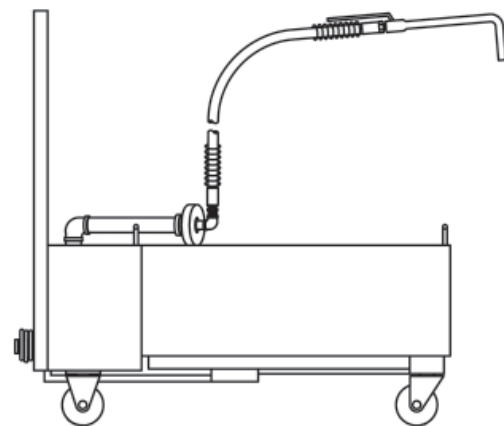

PC14

■ WIRING DIAGRAM

**LB100, LB165, LB200 1 WAY PUMP - PUMP PART # 008196**

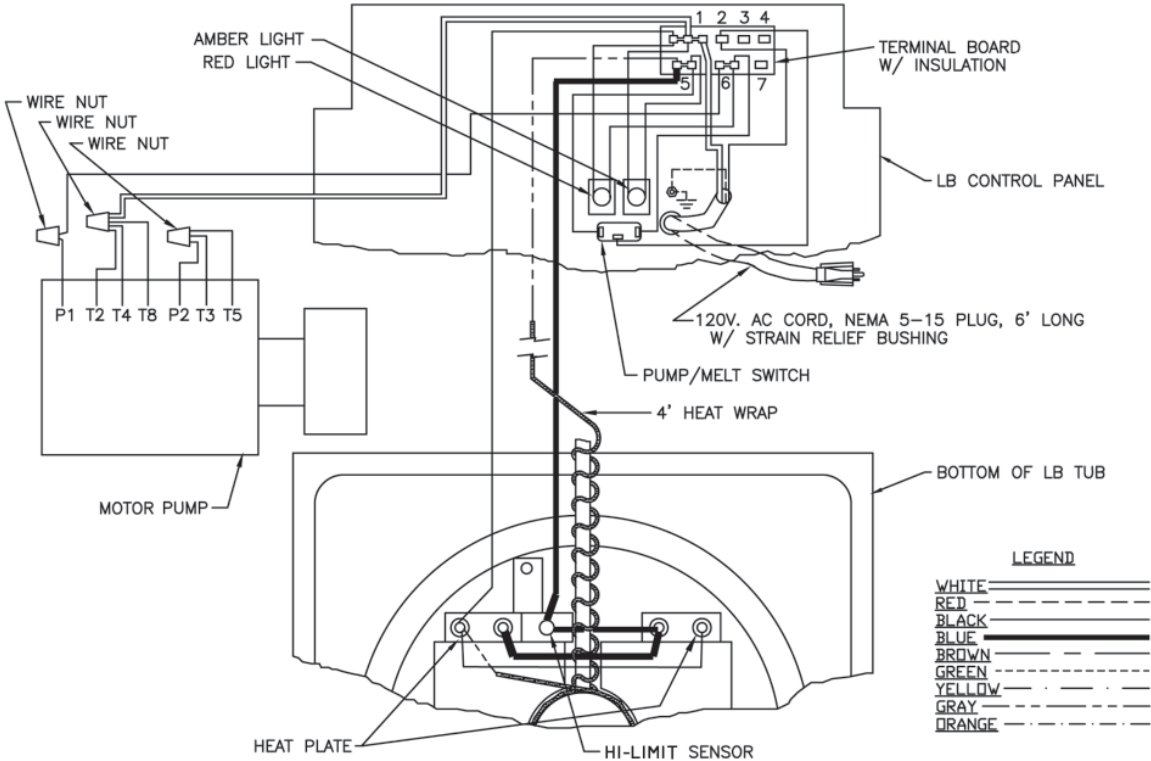

**LB100, LB165 & LB200 2 WAY PUMP - PUMP PART # 055173 (1988-2002)**

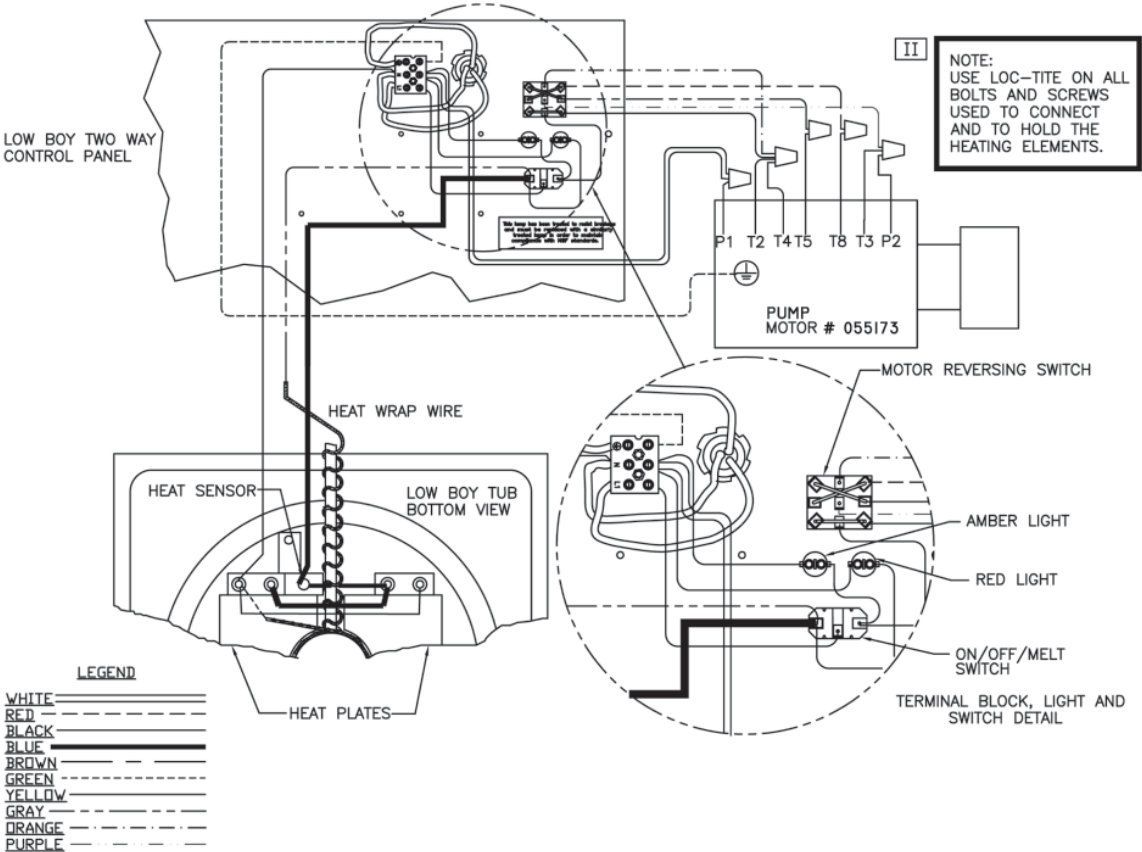

# ■ WIRING DIAGRAM

## LB165 & LB200 1 WAY PUMP (2004 Series) - PUMP PART # 055173

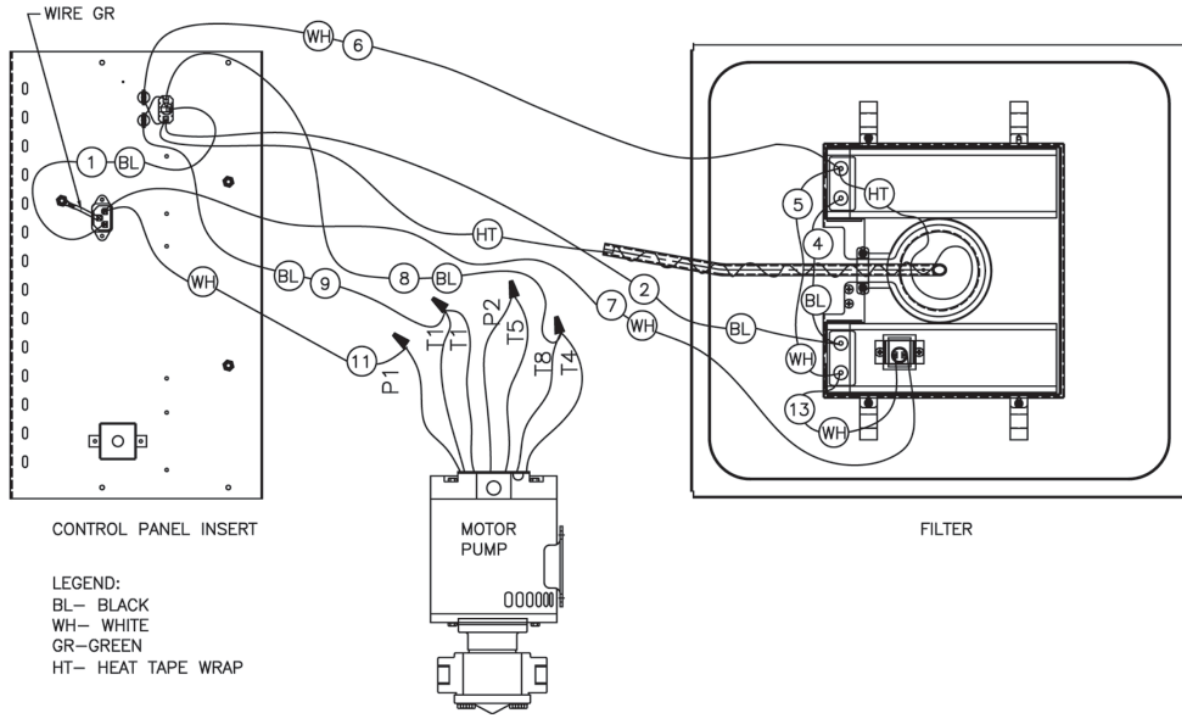

## LB165 & LB200 1 WAY PUMP (After 2005) - PUMP PART # 055173

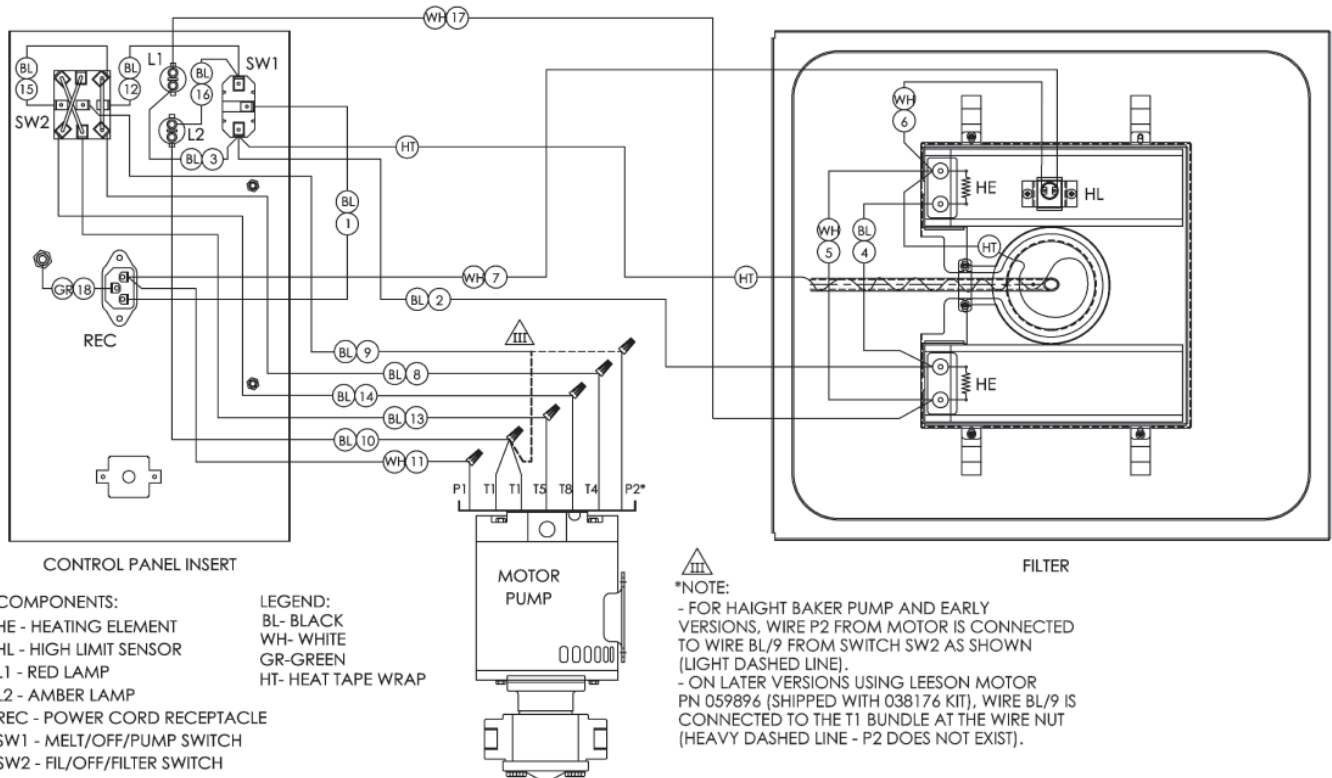

■ WIRING DIAGRAM

**LB165 & LB200 1 WAY PUMP (2003 Series) - PUMP PART # 052982**

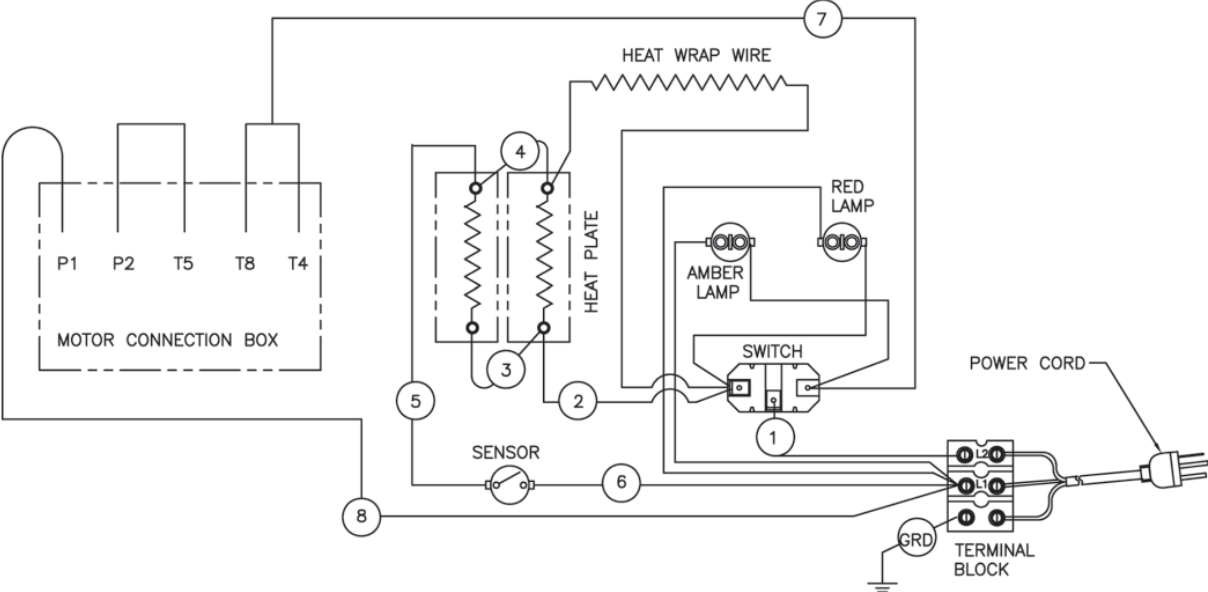

**LB165 & LB200 2 WAY PUMP (After 2004) - PUMP PART # 055173**

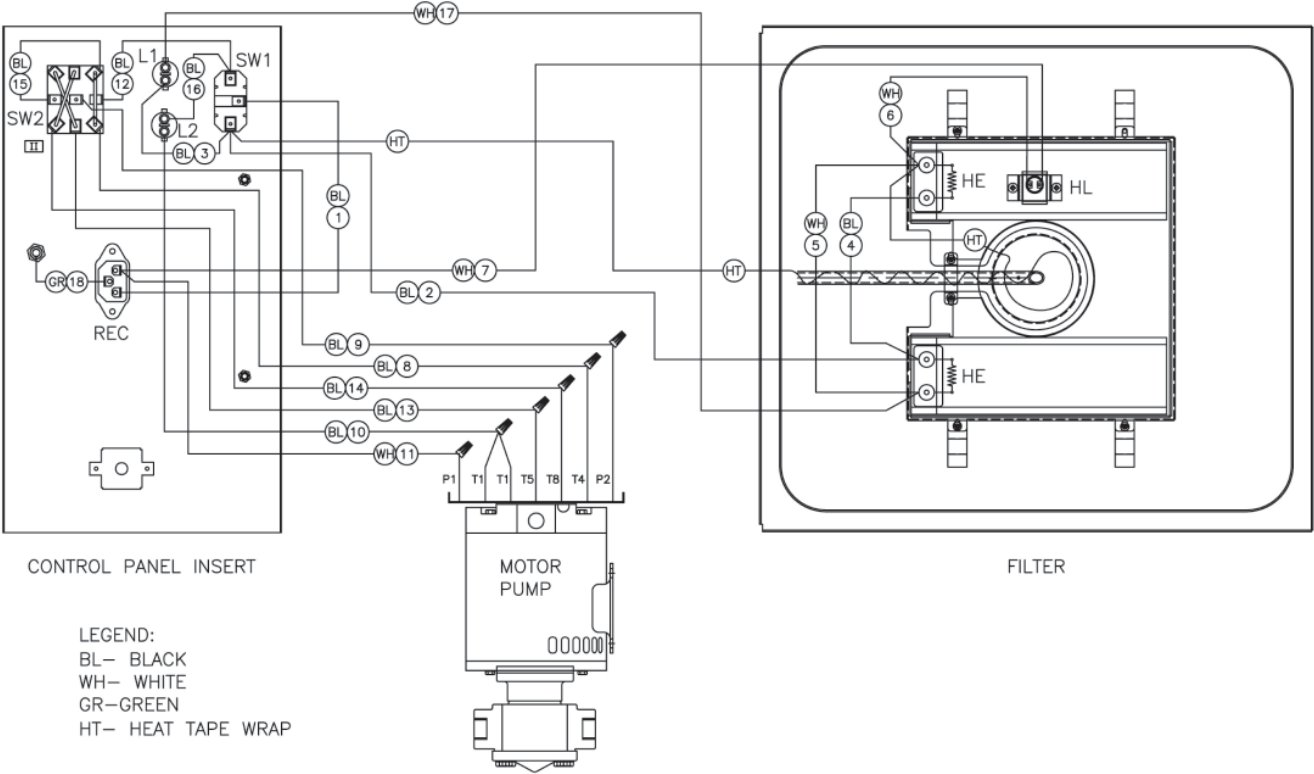

# ■ WIRING DIAGRAM

## LB200 1 WAY PUMP - PUMP PART # 010567 (1993)

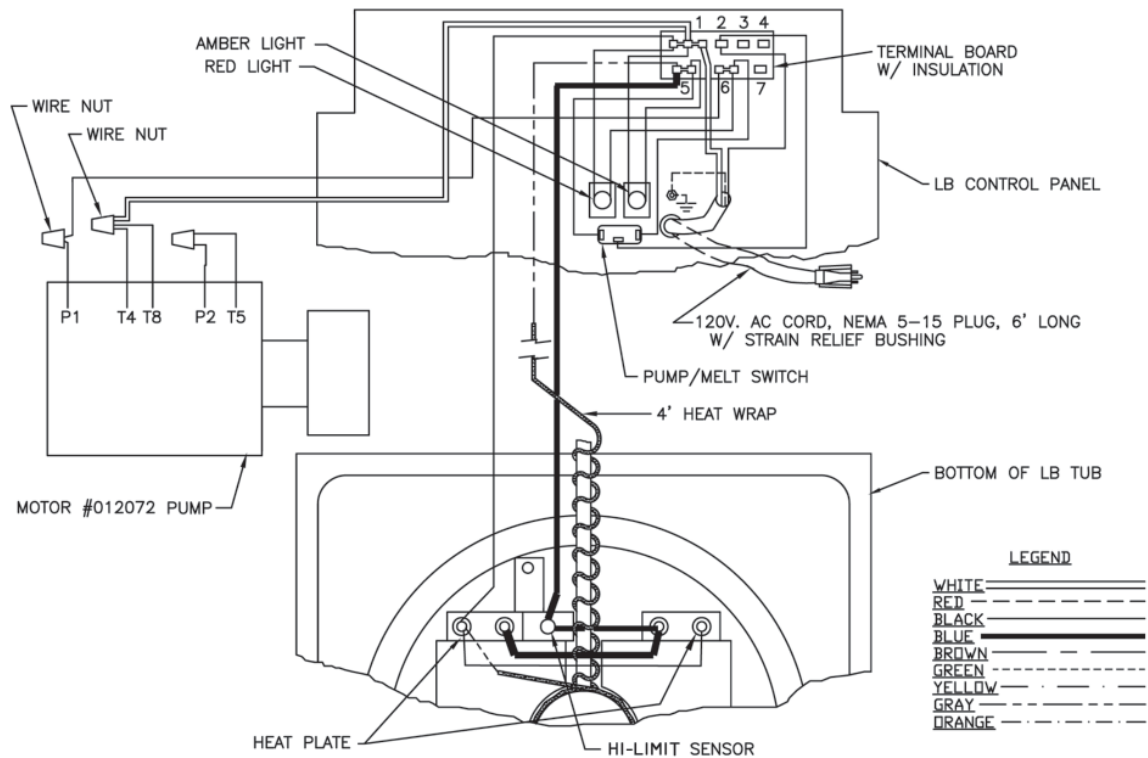

## LB200 2 WAY PUMP - PUMP PART # 010567 (1993)

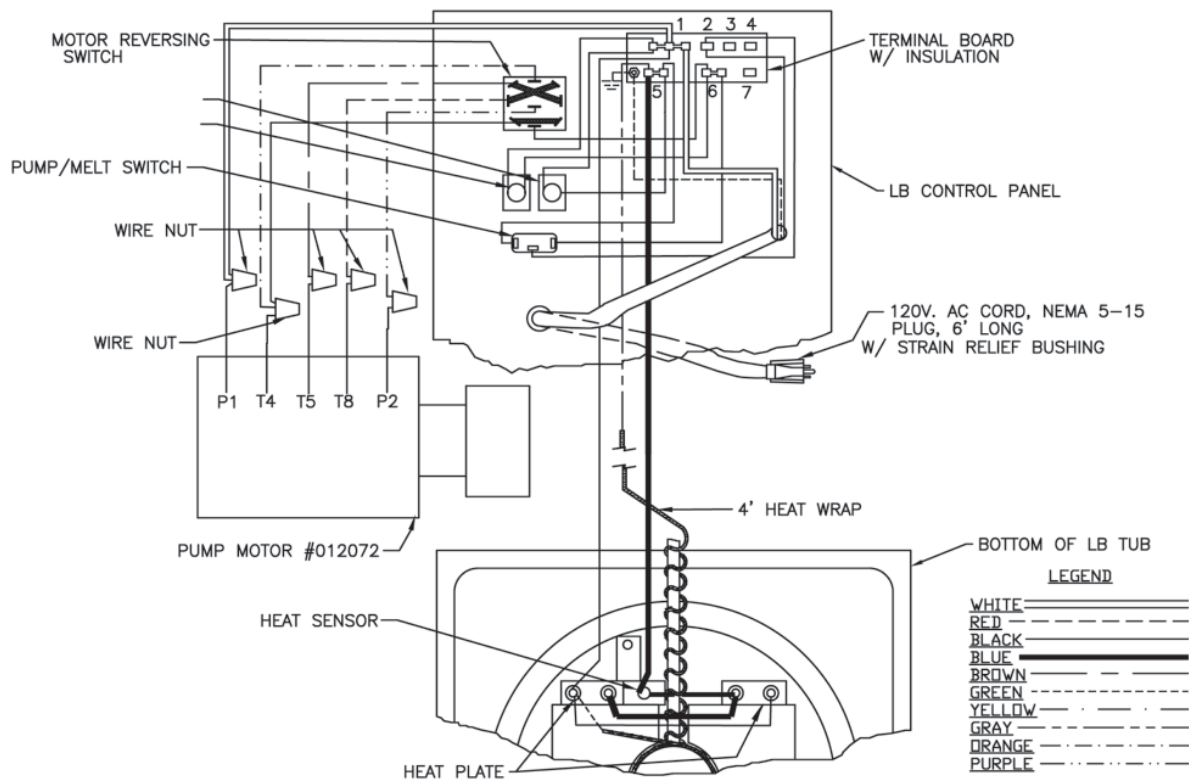



■ WIRING DIAGRAM

PC 14

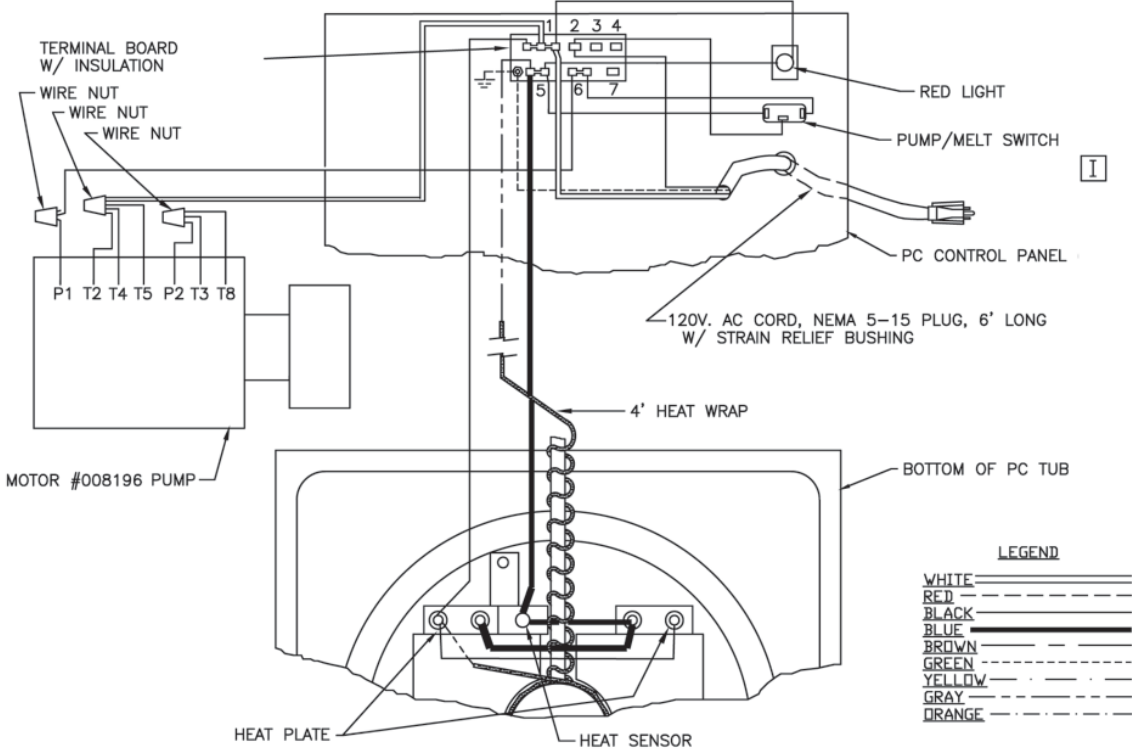



# WARRANTY

## LIMITED WARRANTY

Keating of Chicago, Inc. ("Keating") warrants to the original purchaser, ("Customer"), all new Keating Fryers, Filter Systems, Griddles, Keep Krisp<sup>®</sup>, Custom Pasta Systems, Top-Side<sup>™</sup> Cookers, Computer Timers, Fryer & Pasta Vessels and Keating replacement parts ("products") installed after June 1, 1994 to be free of defects in material or workmanship, subject to the following terms and conditions.

## LENGTH OF WARRANTY

All products other than Fryer & Pasta Vessels and replacement parts shall be warranted for a period of one year from the date of original equipment installation. Keating replacement parts are warranted for a period of ninety days from the date of installation. Fryer & Pasta Vessels are warranted as described below.

## FRYER & PASTA VESSEL WARRANTY

Fryers purchased after June 1, 1994 carry a prorated vessel warranty on defects in materials or workmanship to the Customer based on the following scale:

Time from Installation Date	Fryer Vessel Warranty Credit
13-60 months	100%
61-72 months	80%
73-84 months	60%
85-96 months	40%
97-108 months	20%
109-120 months	10%

The credit for the defective fryer & pasta vessel shall be applied against the cost of the replacement vessel, utilizing Keating's then current price, upon return of the vessel to Keating only during the first 60 months, subject to the limitations described below.

## LIMITATIONS OF LIABILITY

In the event of warranty claim or otherwise, the sole obligation of Keating shall be the repair and / or replacement at the option of Keating of the product or component part thereof. Such repair or replacement shall be at the expense of Keating except that the Customer shall pay the following expenses: all freight and labor expense for Keating replacement parts; for all other products, mileage exceeding 50 miles or travel more than one hour, labor costs of more than one person, overtime rates, truck charges, difference between ground and other mode of transportation, and holiday charges. Any repair or replacement under this Limited Warranty does not constitute an extension of the original warranty for any period for the product or for any component or part thereof. Parts to be replaced under this Limited Warranty will be repaired at the option of Keating with new or functionally operative parts. Keep Krisps and Computer Timers must be returned to Keating for warranty repair or replacement. Field repairs of those items are not authorized.

THE LIABILITY OF KEATING ON ANY CLAIM OF ANY KIND, INCLUDING CLAIMS BASED ON WARRANTY, EXPRESSED OR IMPLIED, CONTRACT, NEGLIGENCE, STRICT LIABILITY OR ANY OTHER THEORIES SHALL BE SOLELY AND EXCLUSIVELY THE REPAIR OR REPLACEMENT OF THE PRODUCT AS STATED HEREIN, AND SUCH LIABILITY SHALL NOT INCLUDE, AND CUSTOMER SPECIFICALLY RENOUNCES ANY RIGHTS TO RECOVER, SPECIAL, INCIDENTAL, CONSEQUENTIAL OR OTHER INJURIES TO PERSONS OR DAMAGE TO PROPERTY, LOSS OF PROFITS OR ANTICIPATED PROFITS, OR LOSS OF USE OF THE PRODUCT.

If any oral statements have been made regarding the Keating products, such statements do not constitute warranties and are not part of the contract sale. This Limited Warranty constitutes the complete, final and exclusive statement with regard to warranties.

THIS LIMITED WARRANTY IS EXCLUSIVE AND IS IN LIEU OF ALL OTHER WARRANTIES WHETHER WRITTEN, ORAL, STATUTORY OR IMPLIED, INCLUDING BUT NOT LIMITED TO ANY WARRANTY OF MERCHANTABILITY OR FITNESS FOR PARTICULAR PURPOSE OR WARRANTY AGAINST LATENT DEFECTS.

## EXCLUSIONS

The warranties provided by Keating of Chicago, Inc. do not apply in the following instances:

1. Defects arising out of or resulting from improper installation or maintenance, abuse, misuse, modification or alteration by unauthorized service personnel, or any other condition not attributable to a defect in material or workmanship. Proper installation and maintenance are the responsibility of the installer and Customer, respectively. Proper installation and maintenance procedures are prescribed by the Keating Service Manual.
2. In the event that the product was damaged after leaving the factory due to flood, fire, other acts of God or accident, damaged during shipment should be reported to the carrier and is not the responsibility of Keating.
3. In the event the serial number or rating plate has been removed from the product or altered.
4. On parts which would normally be worn or replaced under normal conditions, including but not limited to electric bulbs, fuses, interior and exterior finishes, gaskets and radiants.
5. With regard to adjustments and calibrations such as leveling, tightening of fasteners or plumbing connections, improper gas pressure or improper electrical supply, the checking of and changes in adjustment and calibrations are the responsibility of the installer. Proper installation procedures are prescribed by the Keating Service Manual.
6. In the event of unauthorized repairs or alterations to the Keating product.
7. With the use of sodium chloride in pasta vessels or harsh chemicals in fryer or pasta vessels.
8. Installation in Household.

## OTHER TERMS AND CONDITIONS

The Customer must provide proof of purchase from Keating.

This Limited Warranty is valid in the 50 United States, its territories, and Canada, and is void elsewhere. Keating products are sold for commercial use only. If any Keating product is sold as a component of another product or used as a consumer product, such Keating product is sold As Is without any warranty.

If any provision of this Limited Warranty is held to be unenforceable under the law of any jurisdiction, such provision shall be inapplicable in such jurisdiction, and the remainder of the warranty shall remain unaffected. Further in such event, the maximum exclusion or limitation allowable under applicable law shall be deemed substituted for the unenforceable provision.

This Limited Warranty shall be governed by and construed in accordance with the laws of the State of Illinois.

## TO SECURE WARRANTY SERVICE

All repair services under this Limited Warranty must be authorized by Keating or performed at Keating. Authorization may be obtained by calling 1-800-KEATING within the Continental United States, Alaska, Hawaii, Puerto Rico and Canada during normal business hours (8 a.m. through 5 p.m. Central Time, Monday through Friday). When calling, please have the following information available: (1) name, address and telephone number of the Customer; (2) location of product, if different; (3) name, model number and serial number of the product; (4) installation date; and (5) description of defect. Keating will then issue a service authorization work order number to one of its approved independent servicing organizations, or request the product or part be shipped to Keating for repair or replacement, as appropriate. Any defective part subject to a claim under this Limited Warranty must be shipped freight prepaid to Keating for testing and examination. Keating's decision as to the cause and nature of any defect under this Limited Warranty shall be final.



■ **SERVICE INFORMATION:**

If you have a service related question call **1-800-KEATING**.  
Please state the nature of the call; it will ensure speaking with the appropriate person.

---

**Have your serial and model number available when ordering parts.**

---

**As continuous product improvement occurs, specifications may be changed without notice.**

---

.....  
**KEATING LIMITED WARRANTY CARD**

PLEASE COMPLETE AND MAIL AT ONCE—WARRANTY IS NOT IN EFFECT UNTIL CARD IS RETURNED, OR COMPLETE THE WARRANTY CARD ON OUR WEBSITE FOR YOUR CONVENIENCE.

COMPANY: \_\_\_\_\_

ADDRESS: \_\_\_\_\_

CITY: \_\_\_\_\_ STATE: \_\_\_\_\_ ZIP CODE: \_\_\_\_\_

DEALER NAME: \_\_\_\_\_

DATE OF PURCHASE: \_\_\_\_\_ INVOICE #: \_\_\_\_\_

SERIAL #: \_\_\_\_\_ MODEL: \_\_\_\_\_

FRYER                       GRIDDLE                       CUSTOM PASTA  
 FILTER SYSTEM            TOP-SIDE COOKER            HOTPLATE

I HAVE READ THE INSTALLATION AND OPERATING INSTRUCTIONS.

SIGNED: \_\_\_\_\_ DATE: \_\_\_\_\_



**KEATING OF CHICAGO, INC.**  
8901 West 50th Street  
McCook, IL 60525-6001

**1-800-KEATING**  
**PHONE: 708-246-3000**  
**FAX: 708-246-3100**

*Serving Those Who Serve the Very Best®*