



"Serving Those Who Serve The Very Best"

HANDS FREE CENTRAL FILTER OPERATING INSTRUCTIONS

A. FILTER-DRAWER



WARNING!

WATER + HOT OIL = DON'T MIX!



1. Operator should be outfitted with proper protective attire: safety goggles, oil and heat resistant gloves, apron and footwear
2. Release intake hose from filter drawer using the quick disconnect. Refer to Figure 1.
3. Pull filter drawer forward and remove the cover and strainer basket. Refer to Figure 2.
4. Release the spring loaded T-Arms located in the corners of the filter drawer and remove the hold down ring. Refer to Figure 2.
5. Filter screen should be in bottom of drawer. Place filter paper on top of screen.
6. Position hold down ring on top of paper and secure with T-Arms. Refer to Figure 3.

NOTE: Hold down ring makes a gasket-like seal on filter paper. Filter paper must be placed edge to edge from front to back, overlapping on sides. Filter Paper must be smooth and flat under hold down ring to get a proper seal.

NOTE: One package of Acidox is needed for every 40 pounds of oil.

7. Sprinkle Keating Acidox Powder evenly over the paper.
8. Replace strainer basket and cover, push drawer fully into cabinet and reconnect intake hose and pull up on hose to check connection.



CAUTION

Pull up on hose to check connection.

NOTE: Cabinet door should be closed during filtration.

NOTE: For best results, new filter paper and Acidox Powder should be used for each fryer.

B. PREPARING OIL FOR FILTRATION

NOTE: Oil in fryer must be between 250° - 350°F.

1. Turn fryer completely off.

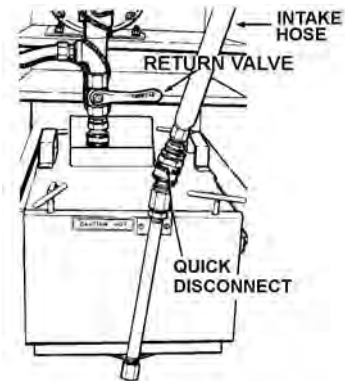

FIGURE 1. QUICK DISCONNECT

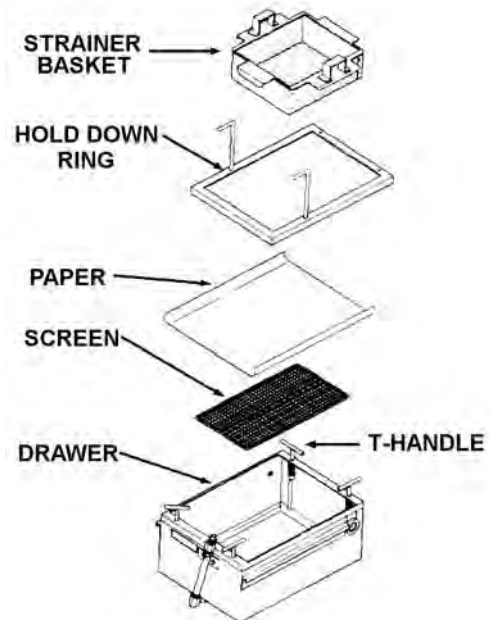

FIGURE 2. FILTER DRAWER ASSEMBLY

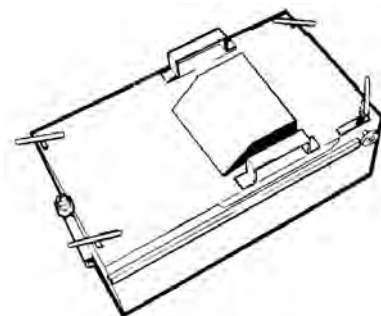

FIGURE 3. FILTER DRAWER COMPLETE WITH SCREEN, FILTER PAPER, HOLD DOWN RING, ACIDOX, STRAINER BASKET AND COVER.

KEEP THIS MANUAL FOR TRAINING NEW PERSONNEL

2. Remove screen from over tubes/element with tongs or a Drain Clean Out Rod. Refer to Figure 4.

⚠ CAUTION

Screen over tubes will be very hot and should be moved to a safe place.

3. Use spoon provided to stir oil. Bubbling will occur until all water is removed. Refer to Figure 5.

NOTE: Water settles in the cooler oil in the Cold Zone. If the water is not removed, the filter paper absorbs the water preventing the oil from passing through it.

C. FILTRATION

1. In fryer cabinet, have return valve handle located directly above the drain valve set to oil flow to fryer. Refer to Figure 6.
2. Open the drain valve by lifting and then pulling the drain valve handle and drain fryer.

NOTE: A Drain Clean Out Rod may be needed to loosen any solid residue. Use it only when valve is fully open.

3. Wipe crumbs from splashdeck while fryer is empty.
4. On the filter panel, turn the pump switch to the “Pump” or “ON” position. Refer to Figure 8.

NOTE: If oil does not return to fryer, set pump switch to “MELT” position for ten minutes to melt any solidified shortening in the return pipe (only on models with melt cycle.)

5. Let the pump run with drain valve open to remove crumbs and residue from the bottom of fryer and the drain lines. Failure to do so may cause the drain lines to clog up.

NOTE: If the pump shuts down, turn it off and let the motor cool. Then pull motor reset lever located in filter cabinet. Check filtering procedure or clean pump if needed.

6. Partially close drain valve to allow fryer to fill above tubes/elements.
7. Let swirling action rinse down fryer.
8. Fully drain fryer.

NOTE: Pump should be run for at least 30 seconds after crumbs are removed from fryer. This will help prevent blockage in the drain lines.

9. Close drain valve and completely refill fryer. Refer to Figure 9.

NOTE: The drain valve handle activates fryer’s Main Power Switch. If drain valve is not fully closed and locked, fryer will not operate.

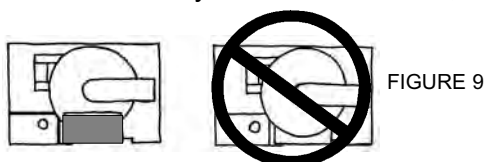

FIGURE 9

10. Turn pump switch to the “OFF” position and close return valve.



FIGURE 4. REMOVE SCREEN OVER TUBES/ELEMENTS



FIGURE 5. STIR WITH SPOON PROVIDED TO REMOVE WATER

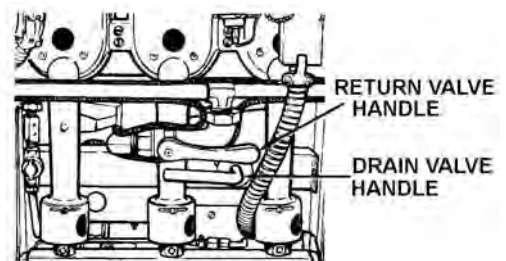

FIGURE 6. FRYER VALVE HANDLES

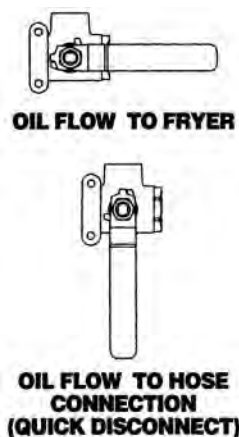

FIGURE 7

D. CLEAN UP

⚠ CAUTION: Filter drawer and pipes will remain hot following filtration. Allow the unit to cool down before clean up. Failure to do so may result in serious injury to the operator.

1. Release intake hose from filter drawer using the quick disconnect. Refer to Figure 10.
2. Pull filter drawer forward and remove the cover and strainer basket. Refer to Figure 2.
3. Release the spring loaded T-Arms located in the corners of the filter drawer and remove the hold down ring. Refer to Figure 2.
4. Thoroughly clean and dry the filter drawer.

NOTE: Tilt the drawer towards the back to fully drain sump. This will prevent solidified oil from blocking the pipe.

5. Replace filter screen after cleaning.
6. Place filter paper on top of screen.
7. Position hold down ring on top of paper and secure with T-Arms. Refer to Figure 3.
8. Sprinkle Keating Acidox powder over the paper.
9. Replace strainer basket and cover, push drawer fully into cabinet and reconnect intake hose. Check to ensure proper connection.
10. Close the cabinet door.

NOTE: Instructions for cleaning the fryer are in the Operating Section of the fryer Service Manual.

E. CLEANING AND BOIL-OUT

When cleaning and boiling out your fryer use Keating Sea Powder and Keating Klenser to keep your fryer in top condition.

Operator should be outfitted with proper protective attire:

- safety goggles
- oil and heat resistant gloves, apron and footwear

Turn the fryer off.

A cleaning hose and wand have been provided for cleaning the fryer and discarding the oil.

Attach cleaning hose to quick disconnect located below the valve handle in filter cabinet.

Remove fry baskets and screen. Drain fryer into the central filter drawer.

Set the return valve to "oil flow to hose." See Figure 6 & 7.

The hose may now be used to rinse the tubes/elements and fry pot and to pump the oil into the shortening handling system and discard properly.

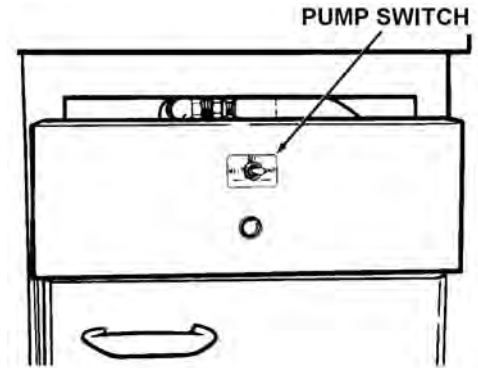

FIGURE 8. FILTER CONTROL PANEL

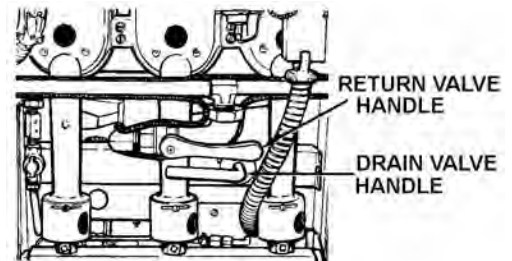

FIGURE 9. DRAIN VALVE HANDLE

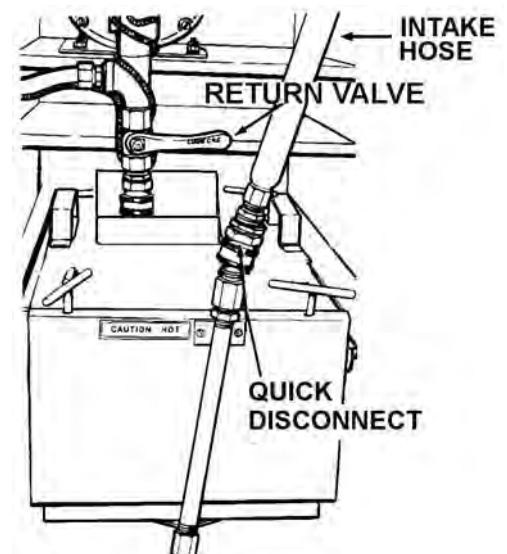

FIGURE 10. QUICK DISCONNECT

⚠ CAUTION: A KEATING FRYER OR FILTER SHOULD BE DRAINED ONLY UNDER THE SUPERVISION OF PROPERLY TRAINED PERSONNEL. WHEN DISCARDING OIL, A COVERED RECEPTACLE APPROVED FOR USE WITH HOT OIL SHOULD BE USED. USE OF A NON-APPROVED RECEPTACLE OR METHOD OF DRAINING THE OIL COULD JEOPARDIZE THE SAFETY OF THE OPERATOR.

CLOSE DRAIN VALVE (REFER TO FIGURE 9)

Fill fryer vessel to "Fill Level" line with water.
Set thermostat and turn fryer on to bring water to a gentle boil.
Once boil has been reached, turn fryer off.

⚠ CAUTION: UNDER NO CIRCUMSTANCES SHOULD THE FRYER AND FILTER BE LEFT UNATTENDED DURING BOIL-OUT. TRAINED PERSONNEL MUST BE PRESENT DURING THE PROCEDURE TO PREVENT BOIL OVER OR TO TURN OFF THE POWER IF WATER DROPS BELOW HEATING TUBES/ELEMENTS.

Dissolve 2/3 cup of Keating Sea Powder for every five gallons of water and let soak for 1/2 hour. If there is a large build-up of carbonized grease, allow fryer to soak overnight.

While soaking, a natural fiber brush may be used to scrub the tubes/elements and inside walls of fryer. Pump the water and Sea Powder into a dry suitable receptacle and remove from cooking area. Sprinkle Keating Klenzer liberally on tubes/elements and sides of fryer vessel. A non-abrasive scouring pad may be used to remove the now softened carbonized grease. Thoroughly rinse fryer vessel with potable water to remove all Klenzer. Prior to refilling with oil, wipe the inside of the fryer vessel making sure all water and Klenzer have been removed.

⚠ CAUTION: Do not damage or reposition thermostat bulb as this may affect the calibration of the fryer.

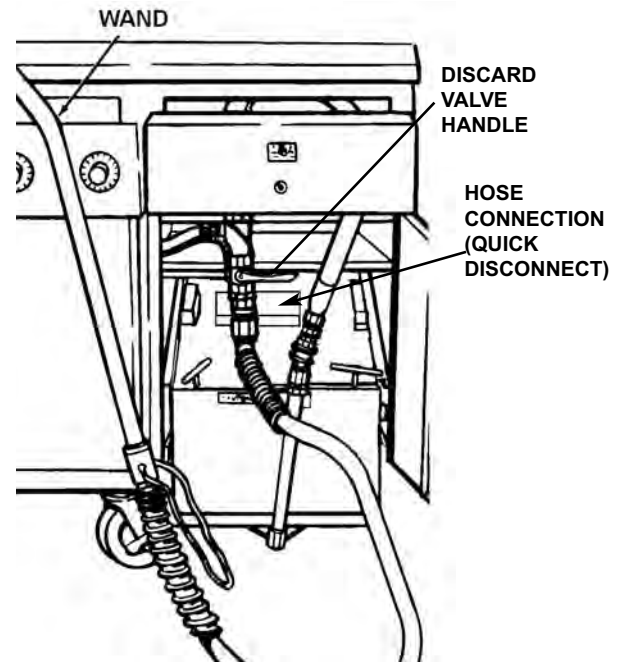

FIGURE 11. CLEANING HOSE AND WAND

⚠ CAUTION: HOT FLUID. DO NOT FILL BEYOND MAXIMUM FILL LINE LOCATED IN THE FRYER VESSEL.



⚠ WARNING!

WATER + HOT OIL = DON'T MIX!

Close the drain valve and disconnect the cleaning hose.

⚠ CAUTION: Failure to close the drain valve before refilling the fryer may result in serious injury. Quick disconnect will remain hot for approximately 15 minutes.

Refill the fryer with new or filtered oil.

Wait until filter drawer is cool before cleaning, approximately 15 minutes.

Remove filter drawer, drain, clean and dry.

Prepare filter drawer and return to filter cabinet.

⚠ CAUTION: To avoid damaging the fryer, do not power wash, spray or hose it down while cleaning it.

Pump must be primed with oil after boil-out with water.

Failure to lubricate pump may cause severe damage to Filter System and void the warranty.

PARTS LIST FOR CENTRAL FILTER

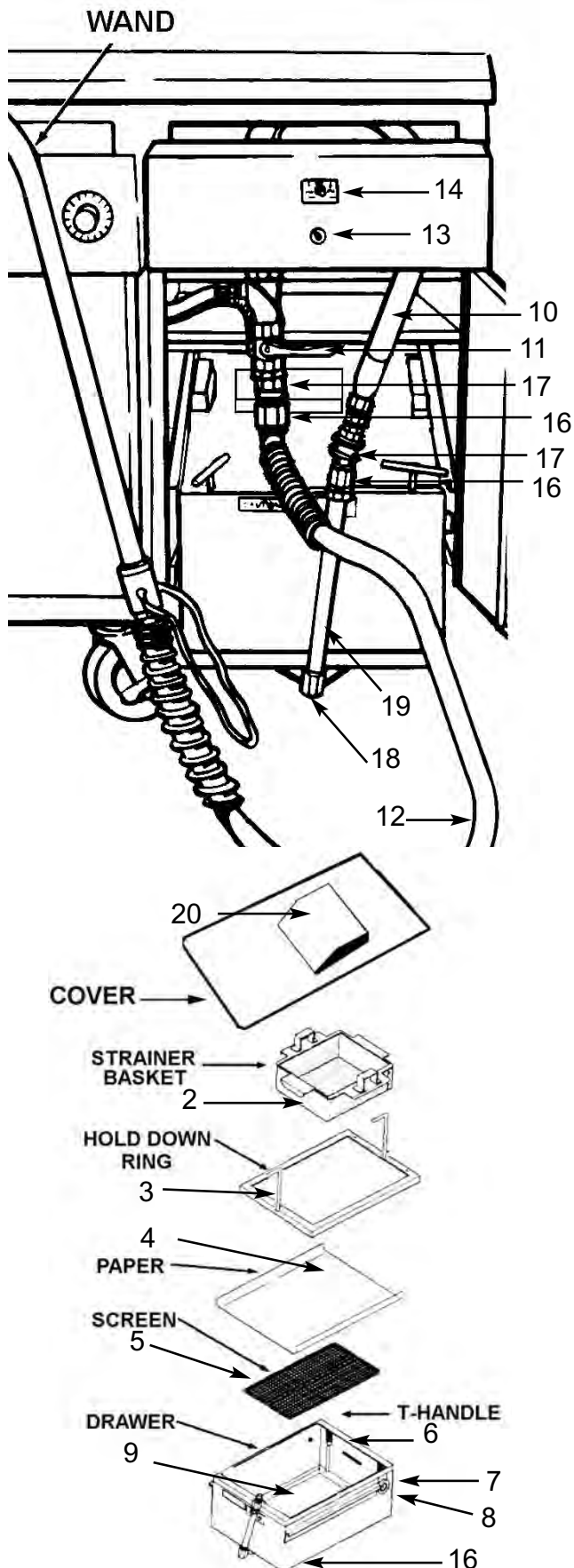

DESCRIPTIONS	PART NO.
1. Motor & Pump Assembly (not shown) (120V and 220V)	008196
2. Strainer Basket	CF14 014498 CF18 018316 CF20 018317 CF24 000454
3. Hold Down Ring	CF14 013230 CF18 018016 CF20 018017 CF24 006711
4. Filter Paper	CF14 052932 CF18 053850 CF20 053850 CF24 053851
5. Filter Screen	CF14 005871 CF18,20,24 028787
6. "T" Handle	CF14, 013132 CF18,20 010628 CF24 009196
7. Spring for "T" Handle	006656
8. Collar with Thumb Screw	029461
9. Filter Drawer	CF14 017638 CF18 017856 CF20 023256 CF24 022791
Cradle for CF24 Filter Drawer (not shown)	023206
Caster for Cradle without brake (not shown)	020866
Caster for Cradle with brake (not shown)	012160
10. Intake Hose	000652
Intake Hose with Quick Disconnect	020023
11. 3-way Valve	009354
12. Cleaning Hose & Wand Complete	CF14 017640 CF18,20,24 023123
13. Indicating Light (Amber) (220V)	004157
Indicating Light (Red)	000525
14. On/Off Switch	004499
15. Power Cord (not shown)	120V 006311 220V 020833
16. Quick Disconnect	(male) 011479
17. Quick Disconnect	(female) 016539
Sea Powder	(4-8 lb. Jars) 000394
Keating Klenzer	(12-14 oz. Cans) 000398
Stir Paddle	029152
18. Compression Elbow 1/2"x3/8"	006477
19. Pipe nipple with clip (Plated) 10"	CF14, 18, 20 016163
Pipe nipple with clip (Plated) 11 3/4"	CF24 016164
20. Cover - Splashguard	CF14 028368 CF18 028370 CF20 028372 CF24 028374

TROUBLESHOOTING GUIDE

PROBLEM	PROBABLE CAUSE	SOLUTION
Motor does not operate.	<ol style="list-style-type: none"> 1. No electrical power to filter. 2. Motor overload tripped. 3. Open wiring. 4. Defective motor or switch. 	<ol style="list-style-type: none"> 1. Verify electrical power is available to filter. 2. Turn filter switch to "OFF" then pull-on motor overload reset lever located in filter cabinet. 3. If motor operates and then overload trips again, check for filter line blockage. If motor does not operate, check wiring for continuity. 4. Replace defective motor/pump or switch.
Filter operates slowly or spurts.	<ol style="list-style-type: none"> 1. 3-way return valve not closed properly or in wrong position. 2. Incorrect operating procedure. 3. Air leak in piping. 	<ol style="list-style-type: none"> 1. Make sure valve handle is in correct position. Refer to filtering instruction card. 2. Verify proper operating procedure. 3. Verify quick disconnect is fully engaged, all piping connections are tight and hoses are not cracked and leaking. Tighten connections or replace defective hoses.
Oil does not pump completely out of filter vessel.	<ol style="list-style-type: none"> 1. Air leak in piping. 2. Filter paper totally clogged. 3. Hold down ring not completely sealing filter paper and air is being drawn into pump. 	<ol style="list-style-type: none"> 1. Verify quick disconnect is fully engaged, all piping connections are tight and hoses are not cracked and leaking. Tighten connections or replace defective hoses. 2. Replace filter paper and apply Acidox Powder being sure to use only one sheet of filter paper and proper quantity of Acidox Powder for filter model. 3. Verify position of paper and proper size. Use correct paper size and confirm seal.

PREVENTIVE MAINTENANCE:

1. To remove water, stir oil until oil bubbling stops; water will clog filter paper pores.
2. Verify all connections, especially quick disconnect, are tight; not leaking oil or sucking air.
3. Use only one sheet of filter paper properly sealed under hold down ring.
4. Use a drain clean out rod if partial or full blockage in fryer drain is suspected.
5. If filter was used for fryer boil out, run oil through filter to lubricate motor/pump.
6. Clean filter after each use. Do not permit oil to remain in filter drawer; it will clog motor/pump.
7. Verify all lights and controls operate.
8. Adhere to operating instructions in sequence given for proper filtration.
9. Prepare filter for next use by using new filter paper and Acidox Powder.

WIRING DIAGRAMS

0132881

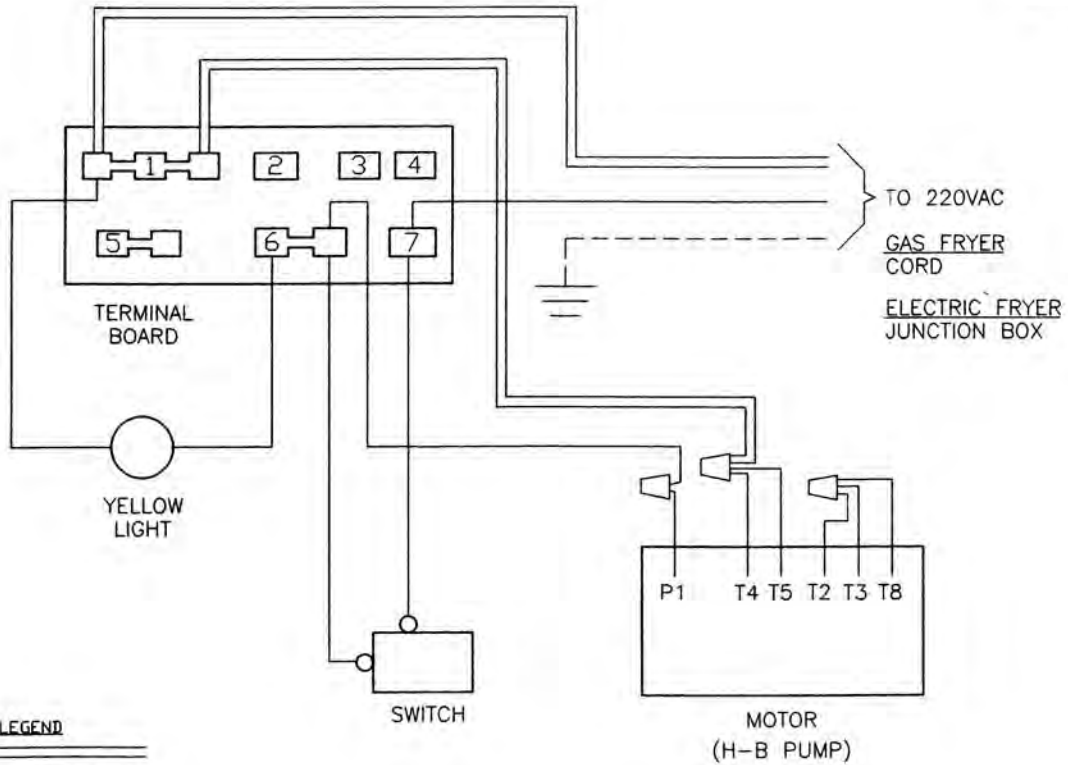

LEGEND
 WHITE _____
 BLACK _____
 GREEN - - - - -

I0001498

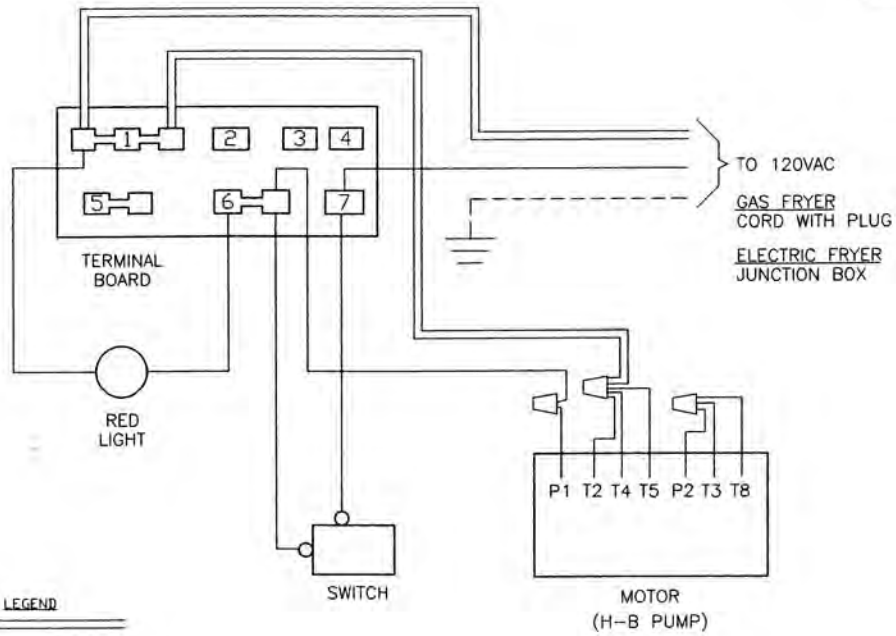

LEGEND
 WHITE _____
 BLACK _____
 GREEN - - - - -

If you have any questions regarding filtering procedures or need assistance, call:
1-800-KEATING.



"Serving Those Who Serve The Very Best"

KEATING OF CHICAGO, INC.
 Tel. 708-246-3000 • Fax 708-246-3100
 Toll Free 1-800-KEATING
 www.keatingofchicago.com

WARRANTY



LIMITED WARRANTY

Keating of Chicago, Inc. ("Keating") warrants to the original purchaser. ("Customer"), all new Keating Fryers, Filter Systems, Griddles, Keep Krisp® Custom Pasta Systems, Top-Side™ Cookers, Computer Timers, Fryer & Pasta Vessels and Keating replacement parts ("products") installed after June 1, 1994 to be free of defects in material or workmanship, subject to the following terms and conditions.

LENGTH OF WARRANTY

All products other than Fryer & Pasta Vessels and replacement parts shall be warranted for a period of one year from the date of original equipment installation. Keating replacement parts are warranted for a period of ninety days from the date of installation. Fryer & Pasta Vessels are warranted as described below.

FRYER & PASTA VESSEL WARRANTY

Fryers purchased after June 1, 1994 carry a prorated vessel warranty on defects in materials or workmanship to the Customer based on the following scale:

Time from Installation Date	Fryer Vessel Warranty Credit
13-60 months	100%
61-72 months	80%
73-84 months	60%
85-96 months	40%
97-108 months	20%
109-120 months	10%

The credit for the defective fryer & pasta vessel shall be applied against the cost of the replacement vessel, utilizing Keating's then current price, upon return of the vessel to Keating. (freight to be paid by Keating within the first 2 months only), only during the first 60 months, subject to the limitations described below.

LIMITATIONS OF LIABILITY

In the event of warranty claim or otherwise, the sole obligation of Keating shall be the repair and / or replacement at the option of Keating of the product or component or part thereof. Such repair or replacement shall be at the expense of Keating except that the Customer shall pay the following expenses: all freight and labor expense for Keating replacement parts; for all other products, mileage exceeding 50 miles or travel more than one hour, labor costs of more than one person, overtime rates, truck charges, difference between ground and other mode of transportation, and holiday charges. Any repair or replacement under this Limited Warranty does not constitute an extension of the original warranty for any period for the product or for any component or part thereof. Parts to be replaced under this Limited Warranty will be repaired at the option of Keating with new or functionally operative parts. Keep Krisps and Computer Timers must be returned to Keating for warranty repair or replacement. Field repairs of those items are not authorized.

THE LIABILITY OF KEATING ON ANY CLAIM OF ANY KIND, INCLUDING CLAIMS BASED ON WARRANTY, EXPRESSED OR IMPLIED, CONTRACT, NEGLIGENCE, STRICT LIABILITY OR ANY OTHER THEORIES SHALL BE SOLELY AND EXCLUSIVELY THE REPAIR OR REPLACEMENT OF THE PRODUCT AS STATED HEREIN, AND SUCH LIABILITY SHALL NOT INCLUDE, AND CUSTOMER SPECIFICALLY RENOUNCES ANY RIGHTS TO RECOVER, SPECIAL, INCIDENTAL, CONSEQUENTIAL OR OTHER INJURIES TO PERSONS OR DAMAGE TO PROPERTY, LOSS OF PROFITS OR ANTICIPATED PROFITS, OR LOSS OF USE OF THE PRODUCT.

If any oral statements have been made regarding the Keating products, such statements do not constitute warranties and are not part of the contract sale. This Limited Warranty constitutes the complete, final and exclusive statement with regard to warranties.

THIS LIMITED WARRANTY IS EXCLUSIVE AND IS IN LIEU OF ALL OTHER WARRANTIES WHETHER WRITTEN, ORAL, STATUTORY OR IMPLIED, INCLUDING BUT NOT LIMITED TO ANY WARRANTY OF MERCHANTABILITY OR FITNESS FOR PARTICULAR PURPOSE OR WARRANTY AGAINST LATENT DEFECTS.

EXCLUSIONS

The warranties provided by Keating of Chicago, Inc. do not apply in the following instances:

1. Defects arising out of or resulting from improper installation or maintenance, abuse, misuse, modification or alteration by unauthorized service personnel, or any other condition not attributable to a defect in material or workmanship. Proper installation and maintenance are the responsibility of the installer and Customer, respectively. Proper installation and maintenance procedures are prescribed by the Keating Service Manual.
2. In the event that the product was damaged after leaving the factory due to flood, fire, other acts of God or accident, damage during shipment should be reported to the carrier and is not the responsibility of Keating.
3. In the event the serial number or rating plate has been removed from the product or altered.
4. On parts which would normally be worn or replaced under normal conditions, including but not limited to electric bulbs, fuses, interior and exterior finishes, gaskets and radiants.
5. With regard to adjustments and calibrations such as leveling, tightening of fasteners or plumbing connections, improper gas pressure or improper electrical supply, the checking of and changes in adjustment and calibrations are the responsibility of the installer. Proper installation procedures are prescribed by the Keating Service Manual.
6. In the event of unauthorized repairs or alterations to the Keating product.
7. With the use of sodium chloride in pasta vessels or harsh chemicals in fryer or pasta vessels.
8. Installation in Household.

OTHER TERMS AND CONDITIONS

The Customer must provide proof of purchase from Keating.

This Limited Warranty is valid in the 50 United States, its territories, and Canada, and is void elsewhere.

Keating products are sold for commercial use only. If any Keating product is sold as a component of another product or used as a consumer product, such Keating product is sold As Is without any warranty.

If any provision of this Limited Warranty is held to be unenforceable under the law of any jurisdiction, such provision shall be inapplicable in such jurisdiction, and the remainder of the warranty shall remain unaffected. Further in such event, the maximum exclusion or limitation allowable under applicable law shall be deemed substituted for the unenforceable provision.

This Limited Warranty shall be governed by and construed in accordance with the laws of the State of Illinois.

TO SECURE WARRANTY SERVICE

All repair services under this Limited Warranty must be authorized by Keating or performed at Keating. Authorization may be obtained by calling 1-800-KEATING within the Continental United States, Alaska, Hawaii, Puerto Rico and Canada during normal business hours (8 a.m. through 5 p.m. Central Time, Monday through Friday). When calling, please have the following information available: (1) name, address and telephone number of the Customer; (2) location of product, if different; (3) name, model number and serial number of the product; (4) installation date; and (5) description of defect. Keating will then issue a service authorization work order number to one of its approved independent servicing organizations, or request the product or part be shipped to Keating for repair or replacement, as appropriate. Any defective part subject to a claim under this Limited Warranty must be shipped freight prepaid to Keating for testing and examination. Keating's decision as to the cause and nature of any defect under this Limited Warranty shall be final.

SERVICE INFORMATION

If you have a service related question call 1-800-KEATING.

Please state the nature of the call; it will ensure speaking with the appropriate person.

Have your serial and model number available when ordering parts.

KEATING OF CHICAGO, INC.

8901 West 50th Street, McCook, Illinois 60525-6001

Phone: (708) 246-3000 FAX: (708) 246-3100

Toll Free 1-800-KEATING (In U.S. and Canada)

www.keatingofchicago.com

***As continuous product improvement occurs, specifications may be changed without notice.**

KEATING LIMITED WARRANTY CARD

PLEASE COMPLETE AND MAIL AT ONCE--WARRANTY IS NOT IN EFFECT UNTIL CARD IS RETURNED.
WARRANTY CARD IS ALSO AVAILABLE ON LINE AT YOUR CONVENIENCE.

COMPANY: _____

ADDRESS: _____

CITY: _____ STATE: _____ ZIP: _____

DEALER: _____

DATE OF PURCHASE: _____ INVOICE NUMBER: _____

SERIAL NUMBER: _____ FRYER FILTER SYSTEM GRIDDLE

REMARKS: _____ TOP-SIDE COOKER HOT PLATE PASTA PLUS

I HAVE READ THE INSTALLATION AND OPERATION INSTRUCTIONS.

SIGNED: _____

DATE: _____ *"Serving Those Who Serve The Very Best"®*